

# Storage & Logistics

Safe, stable, and effective storage





# State of the art manufacturing.

Producción con alto grado de automatización

---

Garantell is a family owned business in Värnamo, south Sweden. We develop and manufacture high-end wire mesh wall solutions that are used across Europe. The product range includes durable and cost effective machine guards, warehouse and industrial storage and logistics solutions as well as property protection systems. We offer all our customers personal service from consultation and design to delivery, installation and maintenance.

Garantell es una empresa de tradición familiar con asiento en la ciudad de Värnamo en el sur de Suecia. Desarrollamos y producimos rejillas metálicas de amplio uso en toda Europa. Nuestro rango de productos incluye rejillas para protección de máquinas con énfasis en durabilidad y optimización de costos, cerramientos para almacenajes industriales y mayoristas, rejillas para estanterías de paletización y sistemas de protección y seguridad. Ofrecemos a todos nuestros clientes un servicio personal desde la consultoría y diseño al despacho, instalación y mantención

---

## **By keeping things simple, we make it easy to do business with us.**

It is important for us to provide convenient and efficient service that makes it easy to be our customer. In order to offer effective solutions quickly, we keep all functions under one roof. From sales, design, manufacturing to after sales support, our team has easy access to all the resources they need to bring your project to completion.

We are happy to share our knowledge and experience and to assist with quick support, quotes and other information whenever you need it.

## **Easy starts with smart engineering.**

The heart of our reliability is quality. All our products are designed for easy installation, to withstand high stress and for long-term durability. We offer product options for different requirements and spaces, which means you do not have to pay for a heavier solution than what is required.

Our products are made in our fully automated facility in Sweden – from wire on rollers to ready mesh sections. They are to a large extent preassembled to reduce assembly time on site.

---

## **Haciendo las cosas simples, facilitamos el hacer negocios con nosotros.**

Para Garantell es esencial proveer un servicio apropiado y eficiente para que sea fácil ser nuestro cliente. Tenemos todo bajo un sólo techo para poder ofrecer soluciones efectivas en forma rápida. Nuestro equipo tiene fácil acceso a todos los recursos - desde las ventas, diseño, producción al servicio postventa - para llevar su proyecto hasta el final.

Es un honor poder compartir nuestro conocimiento y experiencia para atender sus inquietudes y requerimientos en cualquier momento que los necesite.

## **Lo fácil comienza con tecnología inteligente.**

La médula de nuestra confiabilidad está en la calidad. Todos nuestros productos están diseñados para una instalación fácil, para soportar un uso intenso y ser de larga duración. Ofrecemos productos para diferentes opciones y requerimientos y espacios, lo que se traduce en que usted no tiene que pagar por una solución de mayor exigencias que las que realmente necesita.

Nuestros productos se fabrican en nuestras instalaciones en Suecia, en forma totalmente automatizada desde la bobina con alambre a la sección de rejilla metálica y son en gran escala pre-montadas para reducir el tiempo de armado en el lugar de destino.

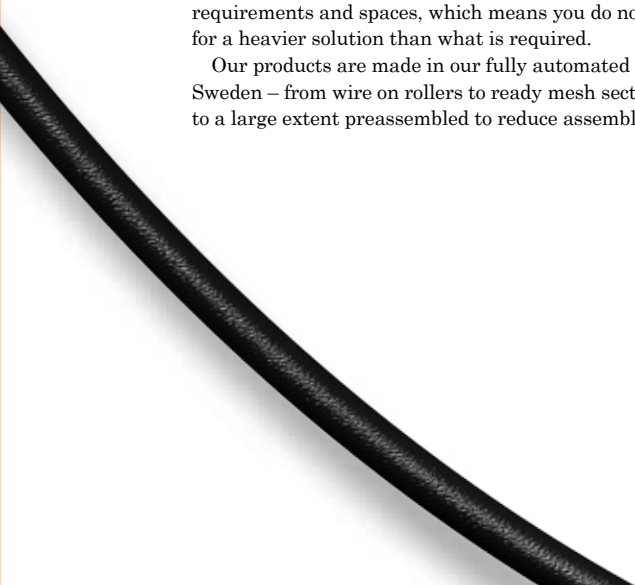

Machine guards  
Protección de máquinas



Property protection  
Bodegas privadas



**Wire mesh decks**  
**Rejillas para estanterías**

6-9



**Rear mesh**  
**Malla anti-caída**

10-19



**Bay mesh**  
**Elementos protección de caída**

20-25



**Side mesh**  
**Mallas laterales**

26-31



**Industrial walls**  
**Cerramientos industriales**

32-83





### Wire mesh decks

Garantells series of wire mesh decking provides additional flexibility regarding dimensions and loading volumes. Our wire mesh systems are galvanized; creating a durable finish that does not require powder coating.

#### Safe, efficient and cost-effective storage.

- Software for strength calculations and customizing decks to your specifications
- Increased flexibility regarding sizes and load capacities
- Tested according to ANSI MH26.2-2007.
- Easy installation.
- All parts are galvanized (8-25 µm) for use indoors.

With our super strong wire mesh deck designs, you can have versatility and functionality that meet your specific storage needs. Our designers have kept all the details in mind, from economy, to the uniqueness of your facility, and what it takes to protect the materials you handle. The decks also give you durability and versatility for changing applications, while meeting safety and fire code requirements.

The wire decks work equally well for storing small items individually or for goods on pallets. They don't collect dust and will allow light and water to pass through, which is often a requirement in areas with sprinkler systems. Wire decks also allow a clear view of upper tiers.

Choose from a variety of standard sizes, or let us design and build a custom deck to your specifications.

### Rejillas para estanterías de paletización

Las rejillas para estanterías de Grantell se ofrecen en amplia y mejorada gama de opciones en cuanto a dimensiones y capacidad de carga. Nuestras rejillas son galvanizadas, lo que les da una superficie de gran duración que no requiere de recubrimiento en polvo.

#### Almacenaje efectivo y seguro con optimización de costos

- Software para el cálculo de resistencia y adaptación de las rejillas para estanterías de paletización a sus especificaciones.
- Mayor flexibilidad en tamaños y capacidades de carga
- Test realizado según ANSI MH26.2-2007.
- Instalación fácil
- Todas las partes están galvanizadas (8-25 µm) para uso interior.

Con el diseño de nuestras rejillas extra resistentes, usted obtiene la versatilidad y funcionalidad que requieren sus necesidades específicas de almacenamiento. Nuestros diseñadores han tomado en cuenta todos los detalles, desde la economía, lo particular de sus instalaciones, y lo que se necesita para proteger los materiales que almacena. Las rejillas para estanterías de paletización ofrecen durabilidad y versatilidad bajo las exigencias de seguridad y medidas de prevención de incendios que se exigen. Las rejillas para estanterías de paletización de Garantell

son aptas para el almacenaje de unidades pequeñas como de los palets completos. No acumulan polvo y permiten el paso de la luz y del agua, una exigencia en áreas con uso de sistemas sprinkler de extinción de incendios. Las rejillas también permiten visibilidad hacia las estanterías superiores.

Elija entre una variedad de medidas estandard, o permítanos diseñar y construir una solución según sus requerimientos..

## Wire mesh decks / Rejillas para estanterías

### Material / Strength

### Material / Resistencia

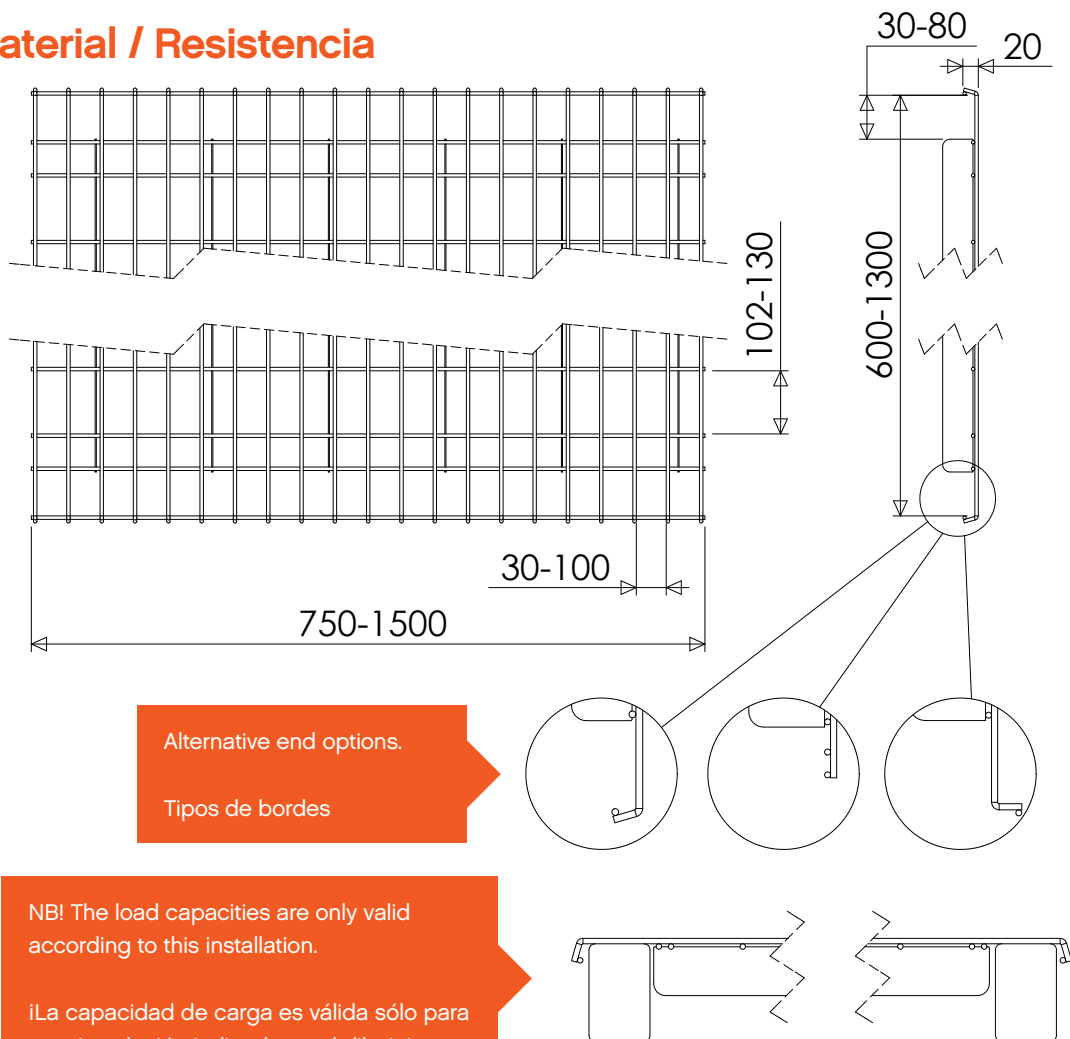

Alternative end options.

Tipos de bordes

NB! The load capacities are only valid according to this installation.

¡La capacidad de carga es válida sólo para esta instalación indicada en el dibujo!

### Load capacities

Example of load capacities for a 1100mm deep deck with 50mm beam width.

Break load limit for uniformed distributed load:  
Up to 1900kg/m<sup>2</sup>  
(with a load factor of 1.5).

Operating load limit for uniformed distributed load:  
Up to 1450kg/m<sup>2</sup>  
(with maximum deflection L/200).

### Capacidad de carga

Ejemplo de capacidad de carga para una rejilla de 1100mm de profundidad con largueros de 50mm.

Límite de carga para carga uniformemente distribuida:  
Hasta 1900kg/m<sup>2</sup>  
(con un factor de carga de 1.5).

Límite de carga operacional para carga uniformemente distribuida:  
Hasta 1450kg/m<sup>2</sup>  
(máxima deflexión L/200)



Clip dividers

Elemento divisor de rejilla

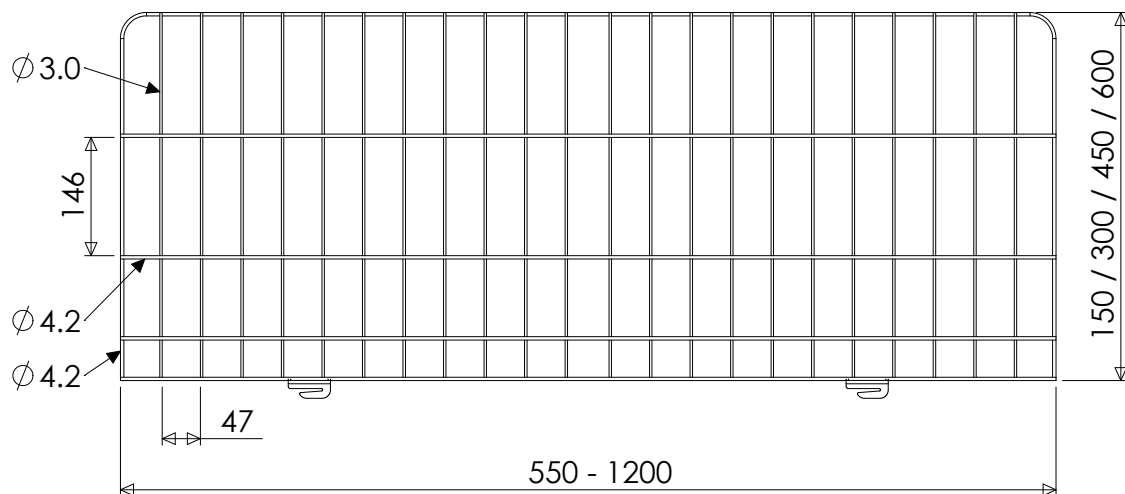



# Rear mesh

Anti collapse mesh in steel is fitted to the rear of the pallet racking to prevent goods from falling out and causing injury to personnel or damage to goods beneath.

Constructed in a brickwork pattern for additional strength, the panels are then bolted together to give the desired width and height. Heights are available in intervals of 100 mm, the width of the end panels is cut to size on site and finished using trim kits.

### Available in three mesh sizes

- Mesh 38x97 mm, for normal circumstances.
- Mesh 18x97 mm, for automated storage systems meeting the safety requirements of a safety distance of 120 mm according to EN ISO 13857:2008, table 4.
- Mesh 18x25 mm, for aerosol storages.

### The mesh panels are mounted by two different methods

- Front of rack, with clamps and sheet metal screws, this method saves installation time.
- Inside the rack, with bolt and nuts. An example of using this method is assembling mesh in between a double rack.

The mesh panels are attached using standoff brackets or bolts directly on to the racking uprights. Standoff brackets fit most common brands of pallet racking on the market.

### Upright extension

For extending the upright when the mesh needs to finish higher.

### Larger opening

Trimming kits for larger openings in the mesh screen.

### Surface

All standard parts are galvanized (8-25 µm) for use indoors. Also available powder coated in any RAL colour.

# Malla anti-caída

Las mallas anti-caída se fijan en la parte posterior de la estantería de paletización para prevenir que la mercancía caiga y dañe a las personas o dañe a otros productos cercanos.

La malla anti-caída tiene su estructura en forma de ladrillos para darle mayor resistencia, luego los paneles se unen con pernos para darle el alto y ancho deseado. El alto se ofrece en intervalos de 100 mm, el ancho del panel final se ajusta al ancho necesario en el lugar y se les da el acabado con los kits correspondientes.

### Disponible en tres tamaños de celdas en la malla.

- Dimensión 38x97 mm, para circunstancias normales.
- Dimensión 18x97 mm, para sistemas automáticos de almacenaje de acuerdo a las exigencias de seguridad con una distancia de seguridad de 120 mm en conformidad a la norma EN ISO 13857:2008, Tabla 4.
- Dimensión 18x25 mm, para almacenaje de aerosoles (donde existe el riesgo de explosión)

### Dos métodos diferentes de montaje para las mallas anti-caída

- Desde el exterior de la estantería de paletización se fijan los elementos con clips y tornillos, este es el método más rápido..
- Desde el lado interior se hace el montaje con pernos y tuercas, lo que a veces es necesario hacer entre las estanterías de paletización dobles.

La malla anti-caída se fija con ayuda de distanciadores o se atornilla directamente a los puntales de las estanterías

Los distanciadores están adecuados a las mayorías de las estanterías de paletización del mercado.

### Extensión de puntales

Si la malla anti-caída va a ser de mayor altura que los puntales de la estantería ofrecemos extensión para estos puntales.

### Aberturas mayores en la malla anti-caída

Conjunto de accesorios diseñados para aberturas mayores en la malla anti-caída.

### Acabado

Como estandard todas las partes están galvanizadas (8-25µm) para uso interior. Nuestros productos tambien se pueden disponer en cada color RAL.

# Rear mesh / Malla anti-caída

## Material

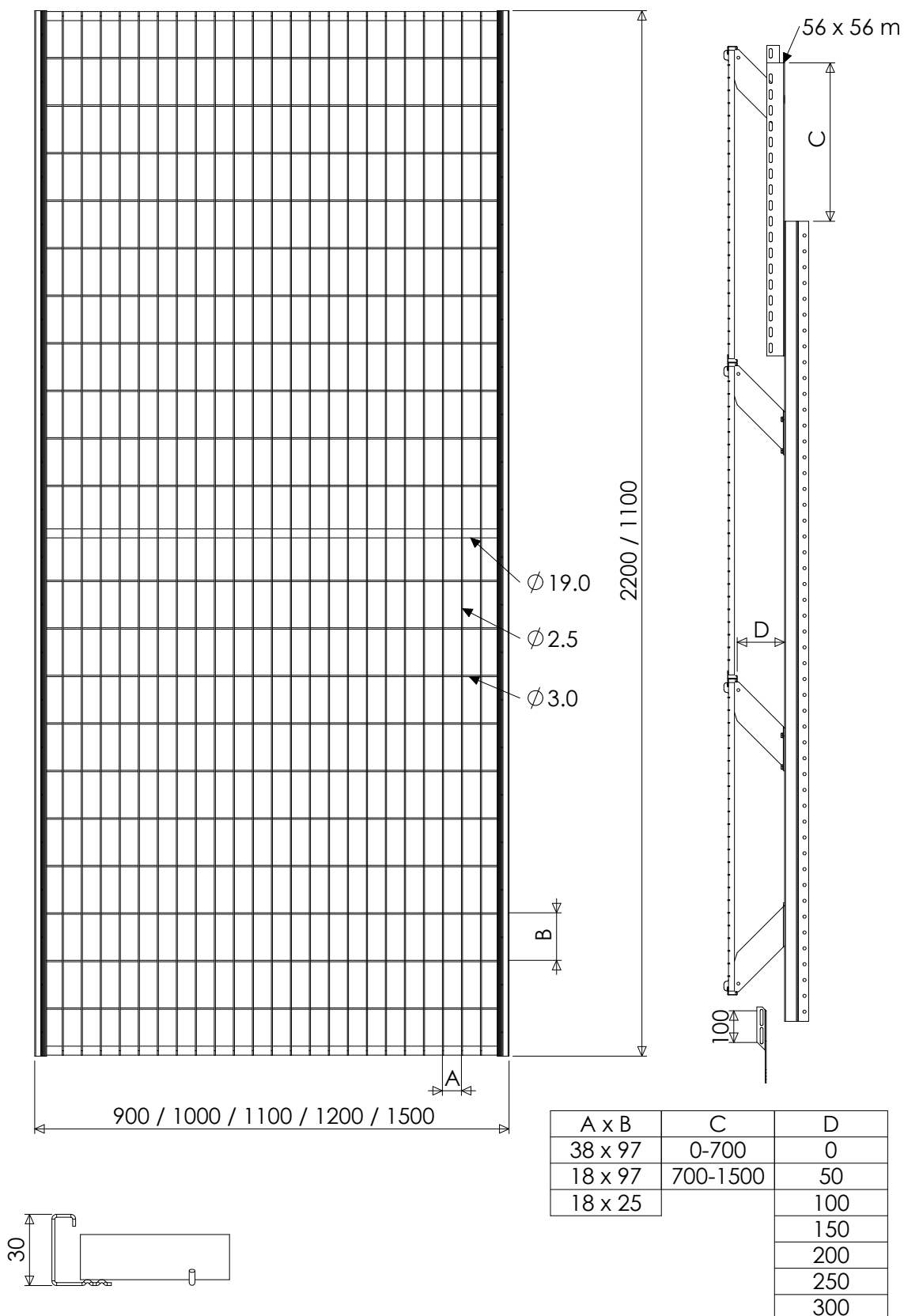

Strength

Resistencia

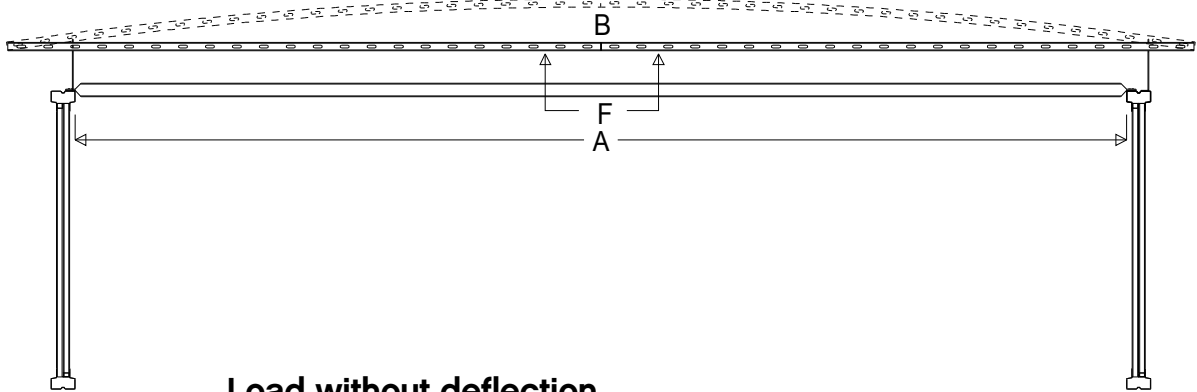

Load without deflection.

Carga sin deflexión.

<b>F</b> (N)	<b>A</b> (mm)	<b>B</b> (mm)
1100	1800	90
	2700	140
	3300	170
	3600	190



Front assembly

Montaje desde el exterior

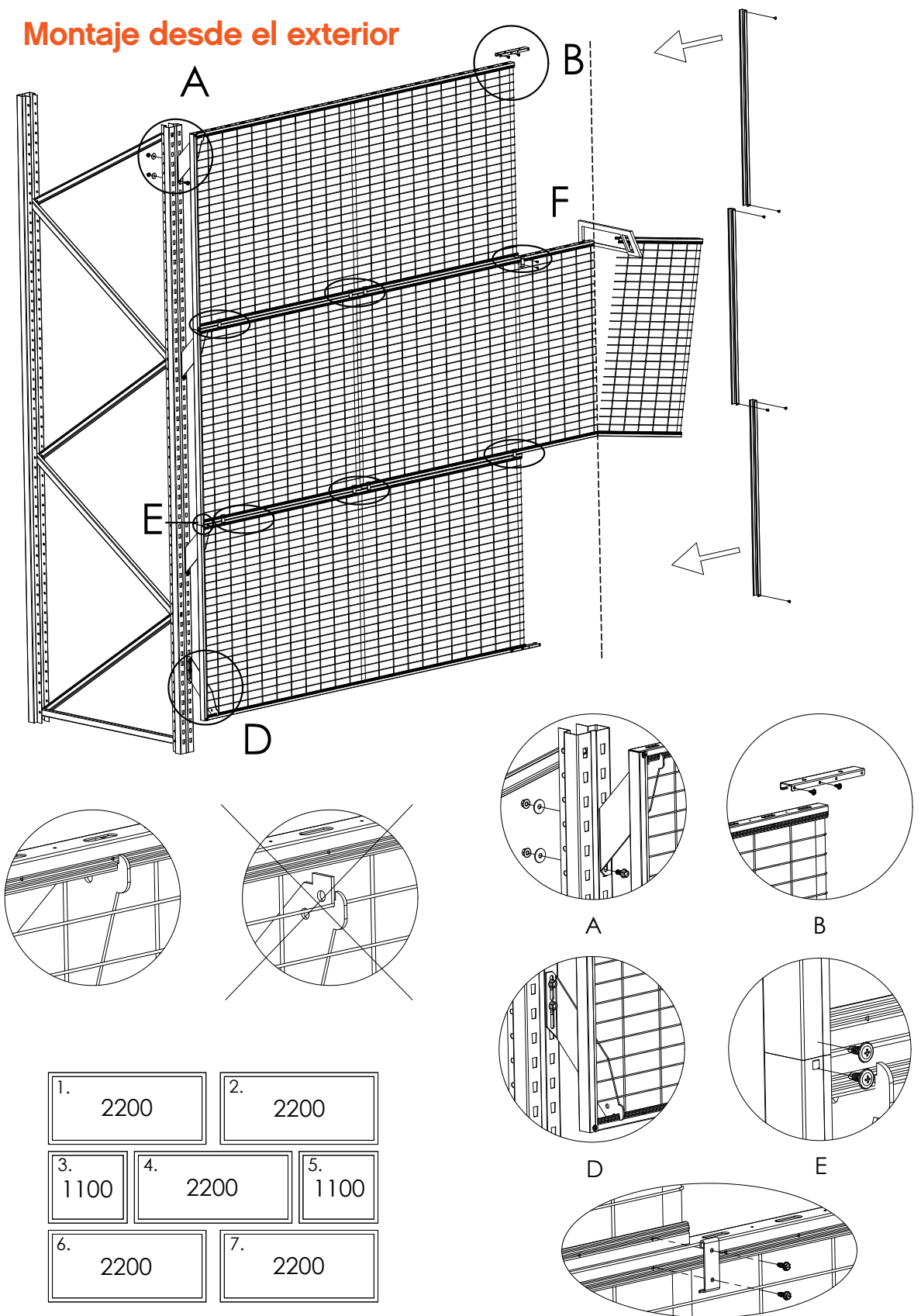

- |         |         |         |
|---------|---------|---------|
| 1. 2200 | 2. 2200 |         |
| 3. 1100 | 4. 2200 | 5. 1100 |
| 6. 2200 | 7. 2200 |         |

Assembly from the inside

Montaje desde el interior

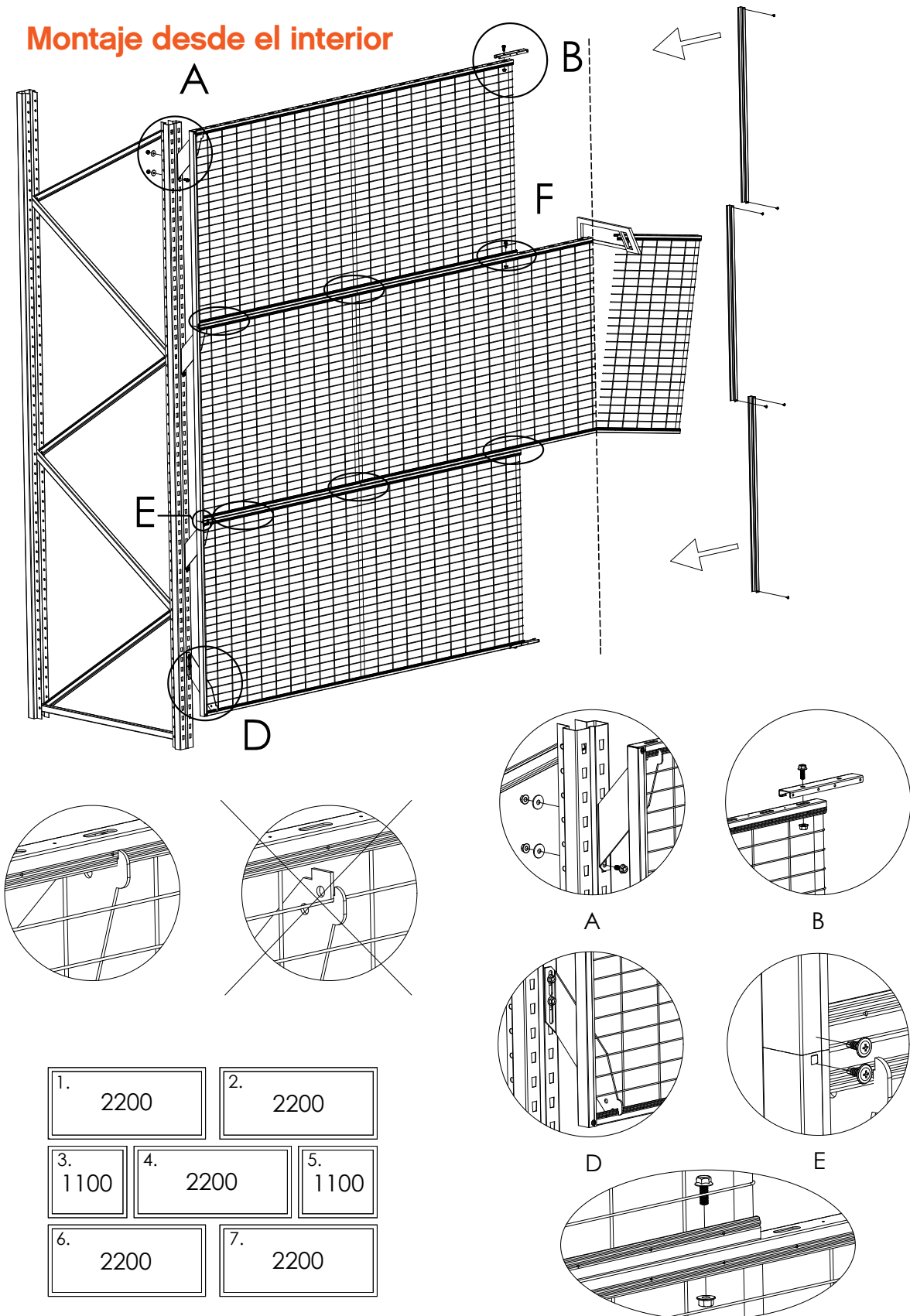

Larger openings

Aberturas mayores

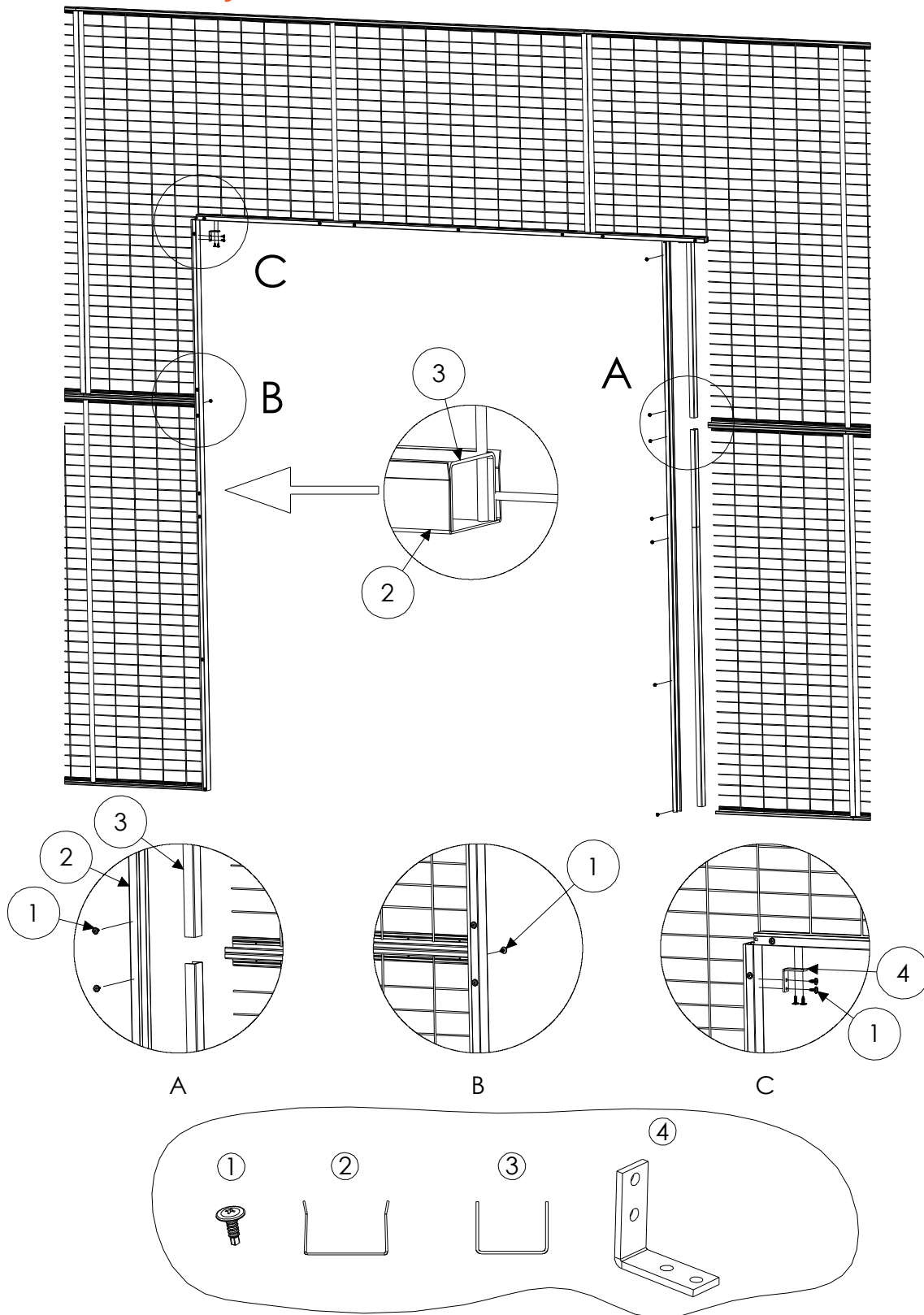



Upright extension

Extensión de puntales

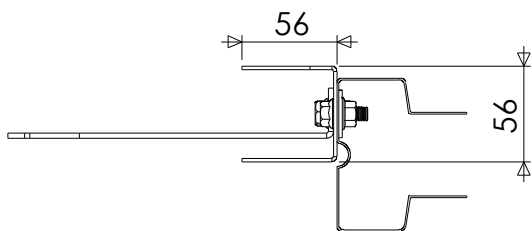
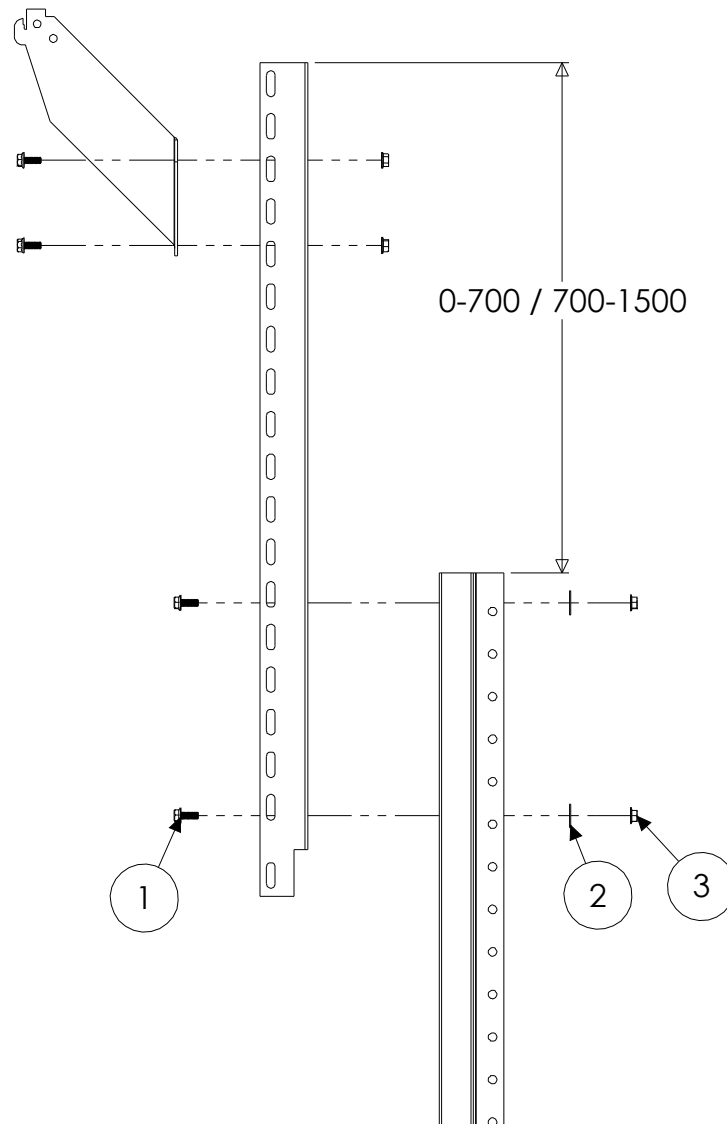

# Rear mesh / Malla anti-caída

## Purchase form

## Formulario de pedido

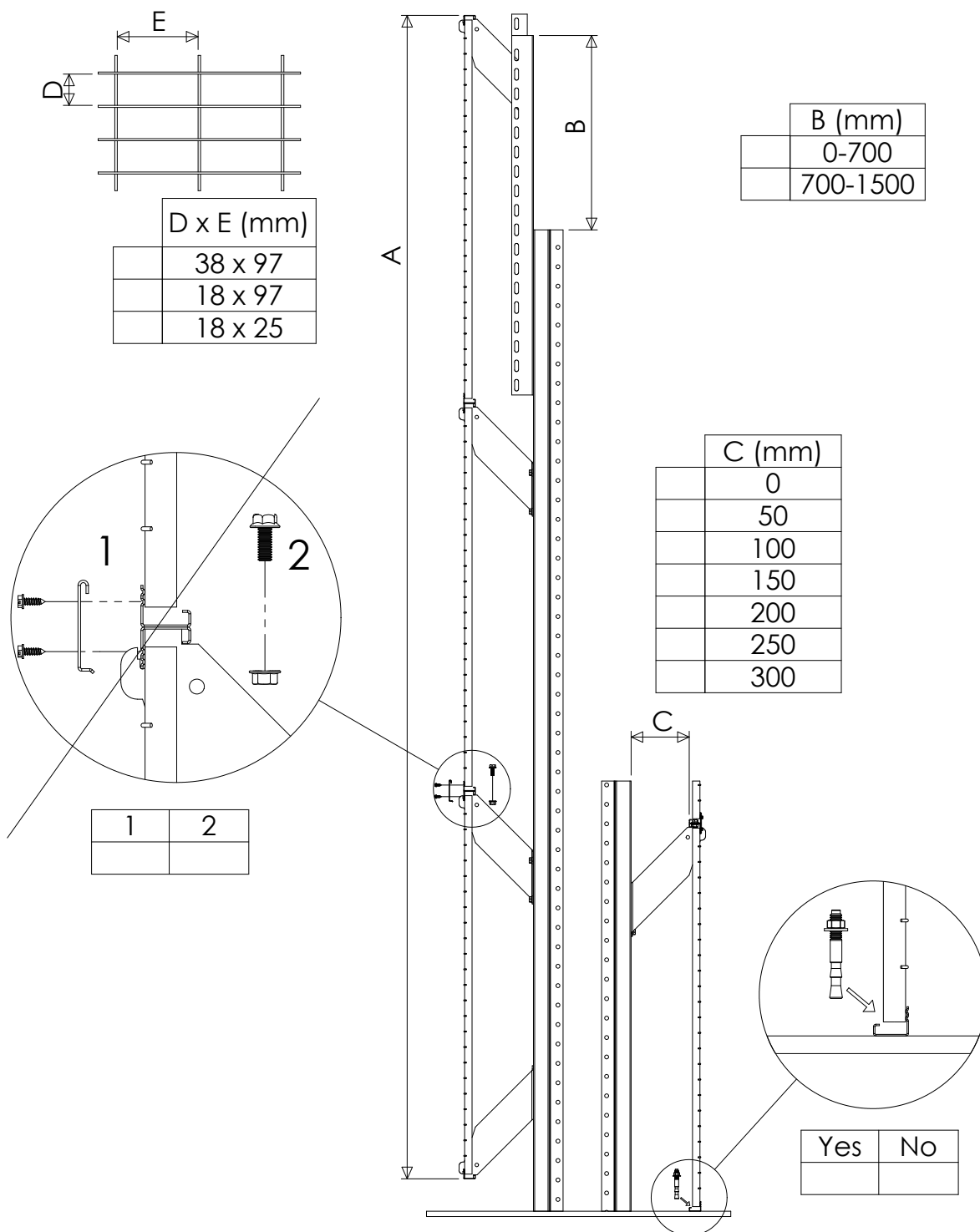

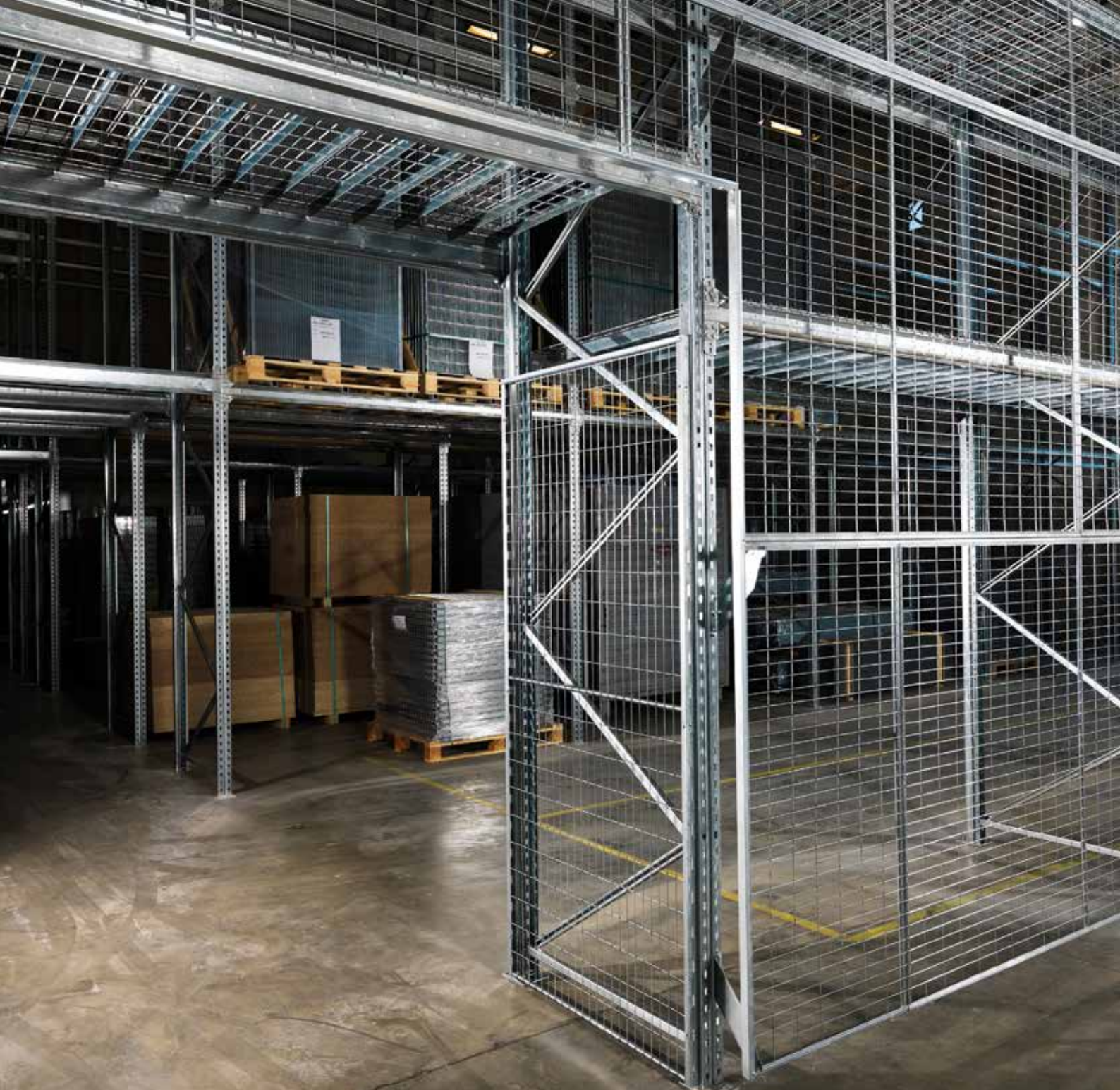



# Bay mesh

Garantells bay mesh in steel prevents goods from falling down. The width of panels is the same as the bay width (beam length), no adjustment on site required.

### Available in three mesh sizes

- Mesh 38x97 mm, for normal circumstances.
- Mesh 18x97 mm, for automated storage systems meeting the safety requirements of a safety distance of 120 mm according to EN ISO 13857:2008, table 4.
- Mesh 18x25 mm, for aerosol storages.

### Upright extension

For extending the upright when the mesh needs to finish higher.

### Surface

All standard parts are galvanized (8-25 µm) for use indoors. Also available powder coated in any RAL colour.

# Elementos de protección de caída

Los elementos de protección de caída dan una protección segura a las mercaderías para prevenir que esta caiga y dañe a las personas o dañe a otros productos cercanos. El ancho de los paneles es igual al de los casilleros (ancho del larguero) No requiere ajustes

### Disponible en tres tamaños de celdas en la malla.

- Dimensión 38x97 mm, para circunstancias normales.
- Dimensión 18x97 mm, para sistemas automáticos de almacenaje de acuerdo a las exigencia de seguridad con una distancia de seguridad de 120 mm en conformidad a la norma EN ISO 13857:2008, Tabla 4.
- Dimensión 18x25 mm, para almacenaje de aerosoles (donde existe el riesgo de explosión)

### Extensión de puntales

Si la malla anti-caída va a ser de mayor altura que los puntales de la estantería, ofrecemos extensión para los puntales.

### Acabado

Como estandard todas las partes están galvanizadas (8-25µm) para uso interior. Nuestros productos también se pueden disponer en cada color RAL.

Material

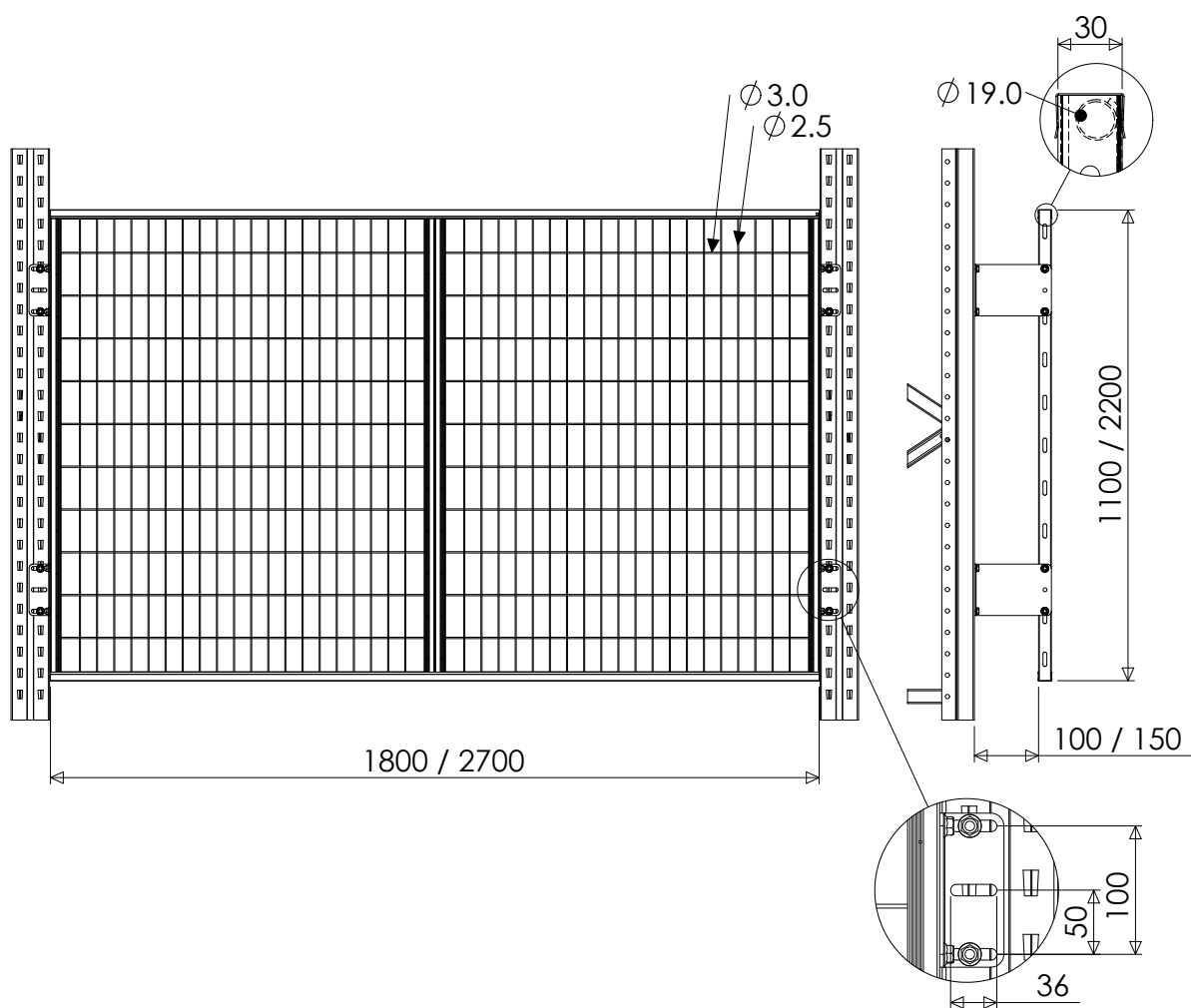

Strength

Resistencia

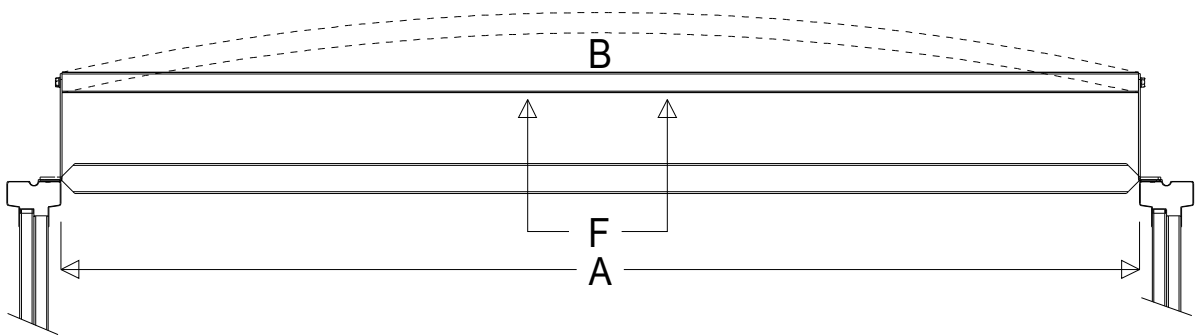

Load without deflection.

Carga sin deflexión.

<b>F</b> (N)	<b>A</b> (mm)	<b>B</b> (mm)
1400	1800	60
1400	2700	80

Assembly instruction

Instrucciones de montaje

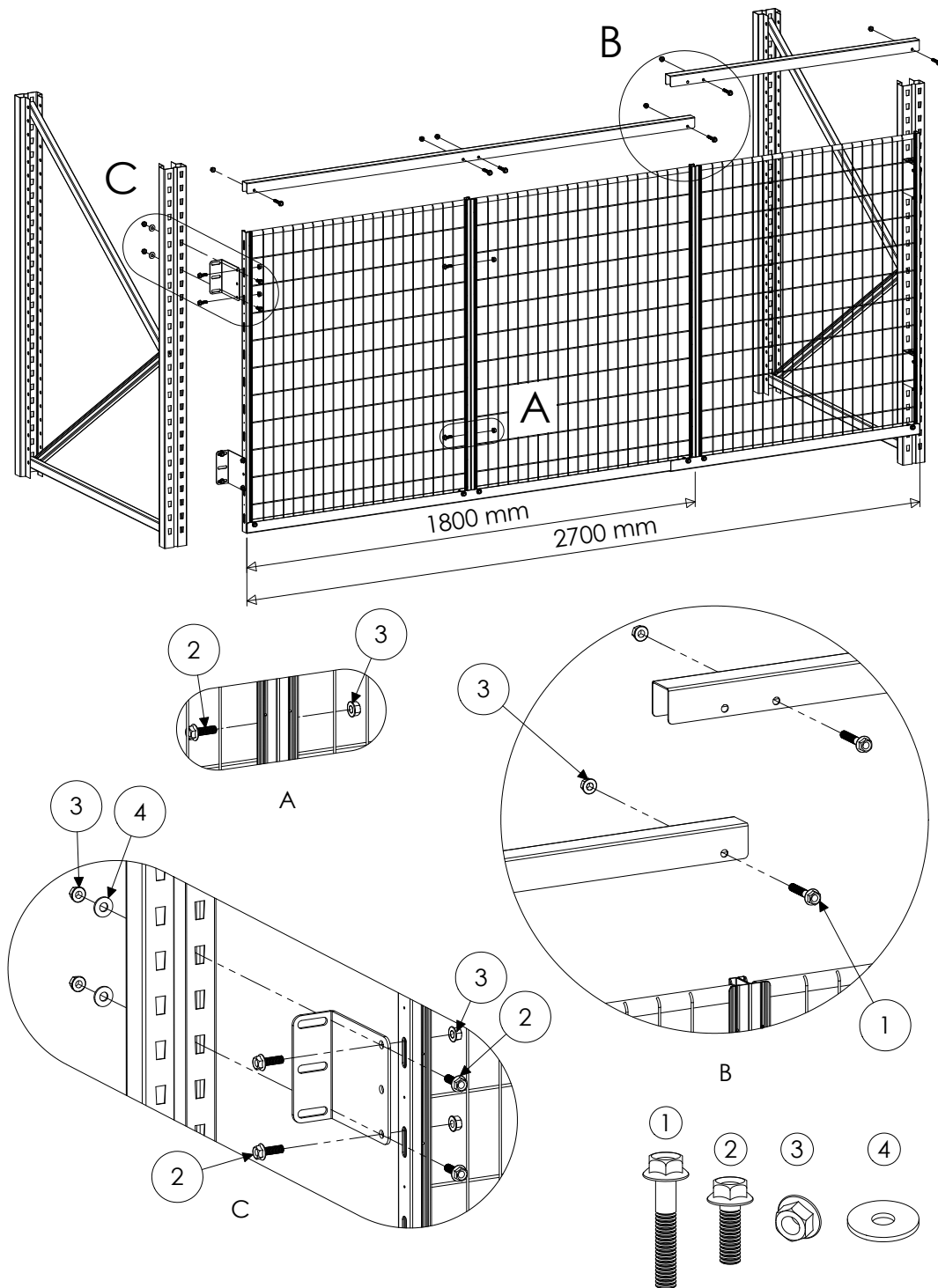



Purchase form

Formulario de pedido

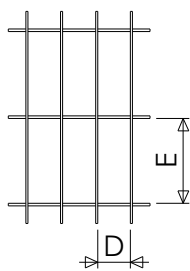
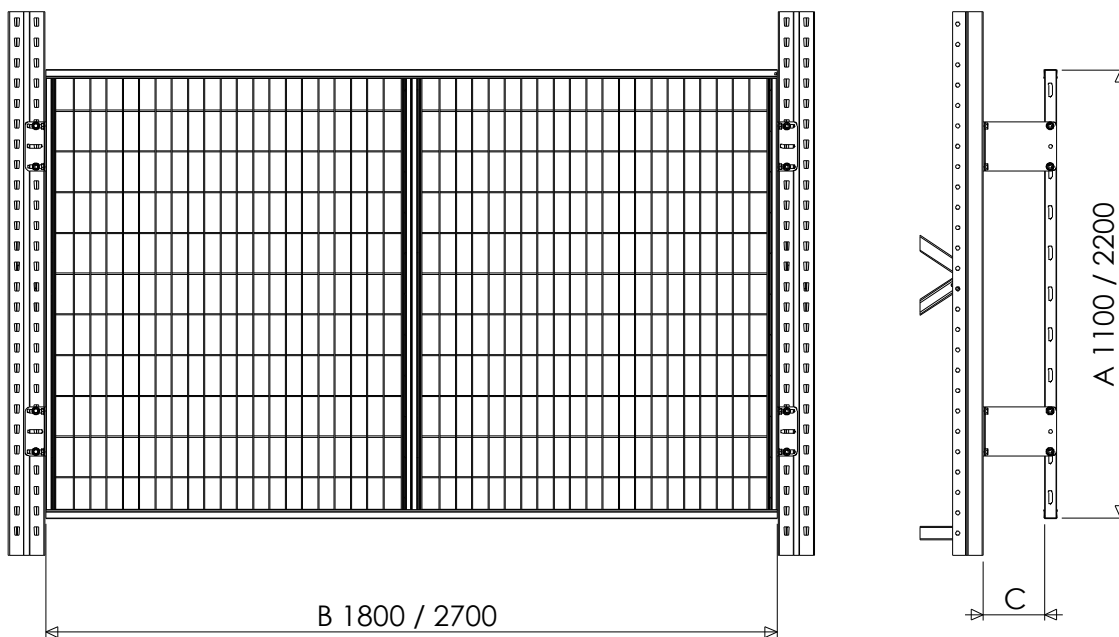

D x E
38 x 97
18 x 97
18 x 25

QTY.	A x B (mm)
	1100 x 1800
	2200 x 1800
	1100 x 2700
	2200 x 2700

C (mm)
100
150



### Side mesh

Garantells anti collapse mesh in steel is fitted to the side of the pallet racking and prevents goods from falling out and causing injury to personnel or damage to goods below.

Constructed using standard panels bolted directly to the uprights, the height of the end panels is cut to size on site and finished with the trim kits.

#### Available in three mesh sizes

- Mesh 38x97 mm, for normal circumstances.
- Mesh 18x97 mm, for automated storage systems meeting the safety requirements of a safety distance of 120 mm according to EN ISO 13857:2008, table 4.
- Mesh 18x25 mm, for aerosol storages.

#### Surface

All standard parts are galvanized (8-25 µm) for use indoors. Also available powder coated in any RAL colour.

### Mallas laterales

Mallas laterales de acero que cumplen la misma función que las mallas anti-caída se fijan al costado de la estantería de paletización para prevenir que la mercadería caiga y dañe a las personas o dañe a otros productos cercanos.

Las mallas laterales se basan en elementos de rejilla estandarizados, que se atornillan directamente a los puntales de las estanterías. El último elemento se corta a la dimensión deseada en el lugar de montaje y se le da el acabado con los kits correspondientes.

#### Disponible en tres tamaños de celdas en la malla.

- Dimensión 38x97 mm, para circunstancias normales.
- Dimensión 18x97 mm, para sistemas automáticos de almacenaje de acuerdo a las exigencia de seguridad con una distancia de seguridad de 120 mm en conformidad a la norma EN ISO 13857:2008, Tabla 4.
- Dimensión 18x25 mm, para almacenaje de aerosoles (donde existe el riesgo de explosión)

#### Acabado

Como estandard todas las partes están galvanizadas (8-25µm) para uso interior. Nuestros productos también se pueden disponer en cada color RAL.

## Side mesh / Mallas laterales

### Material

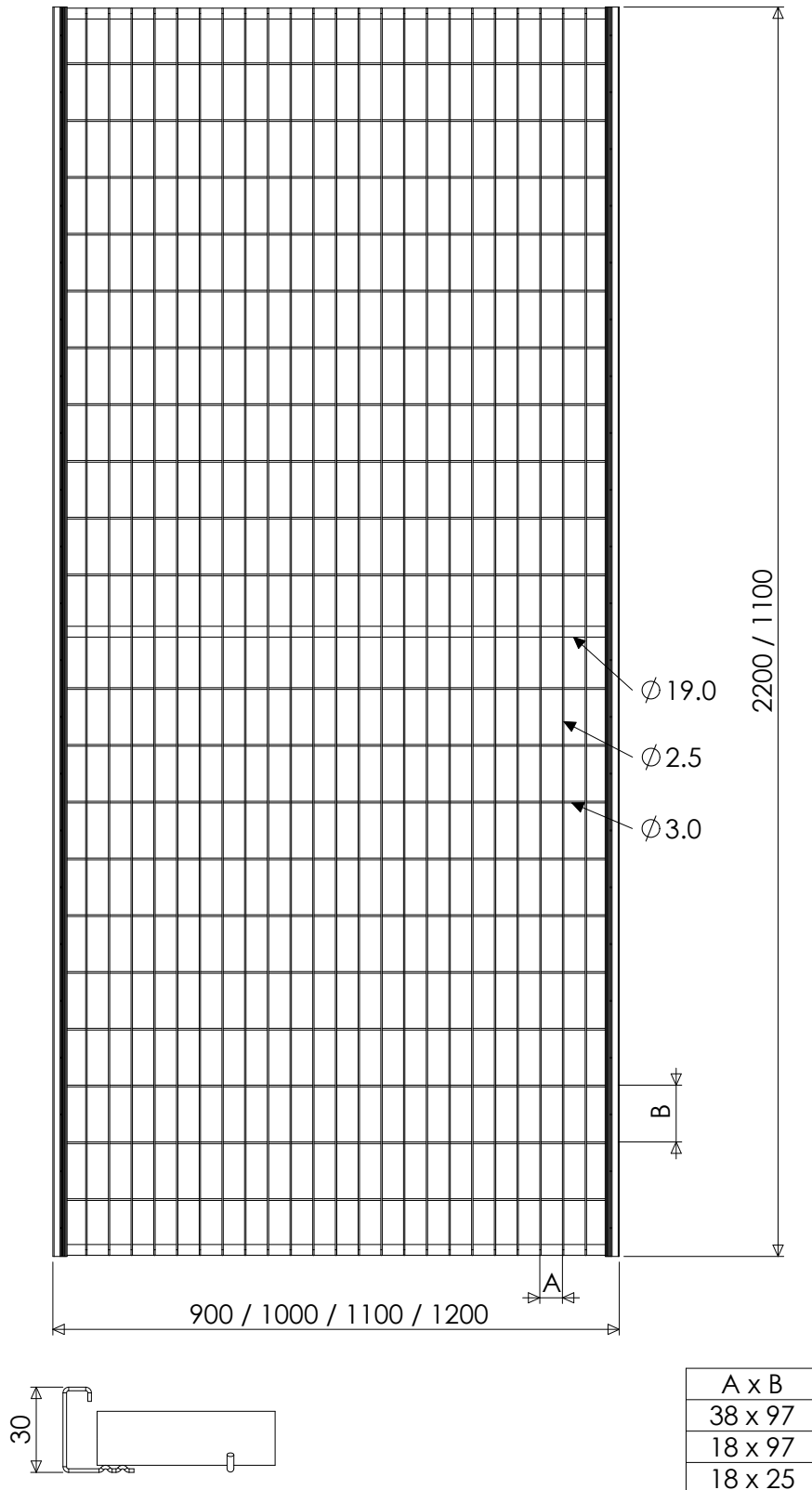

Strength

Resistencia

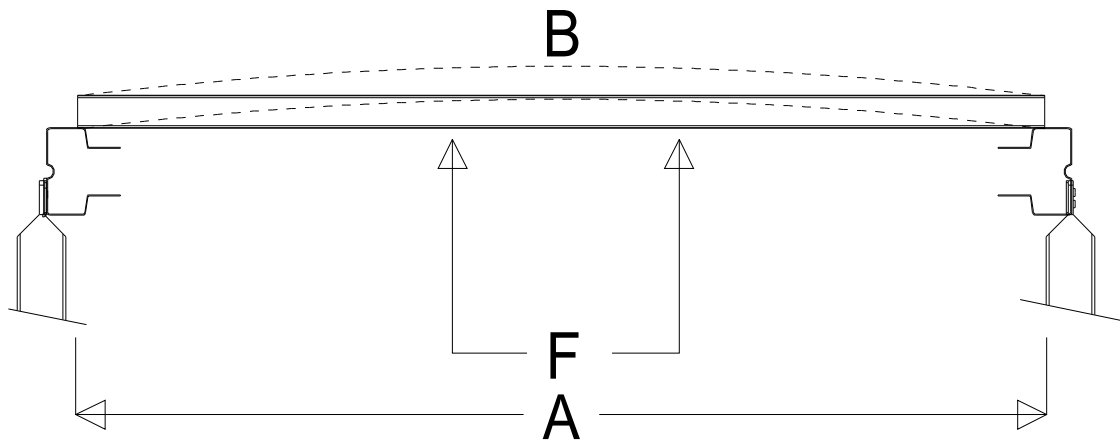

Load without deflection.

Carga sin deflexión.

<b>F</b> (N)	<b>A</b> (mm)	<b>B</b> (mm)
900	900	75
	1000	80
	1100	85
	1200	95

Assembly instruction

Instrucciones de montaje

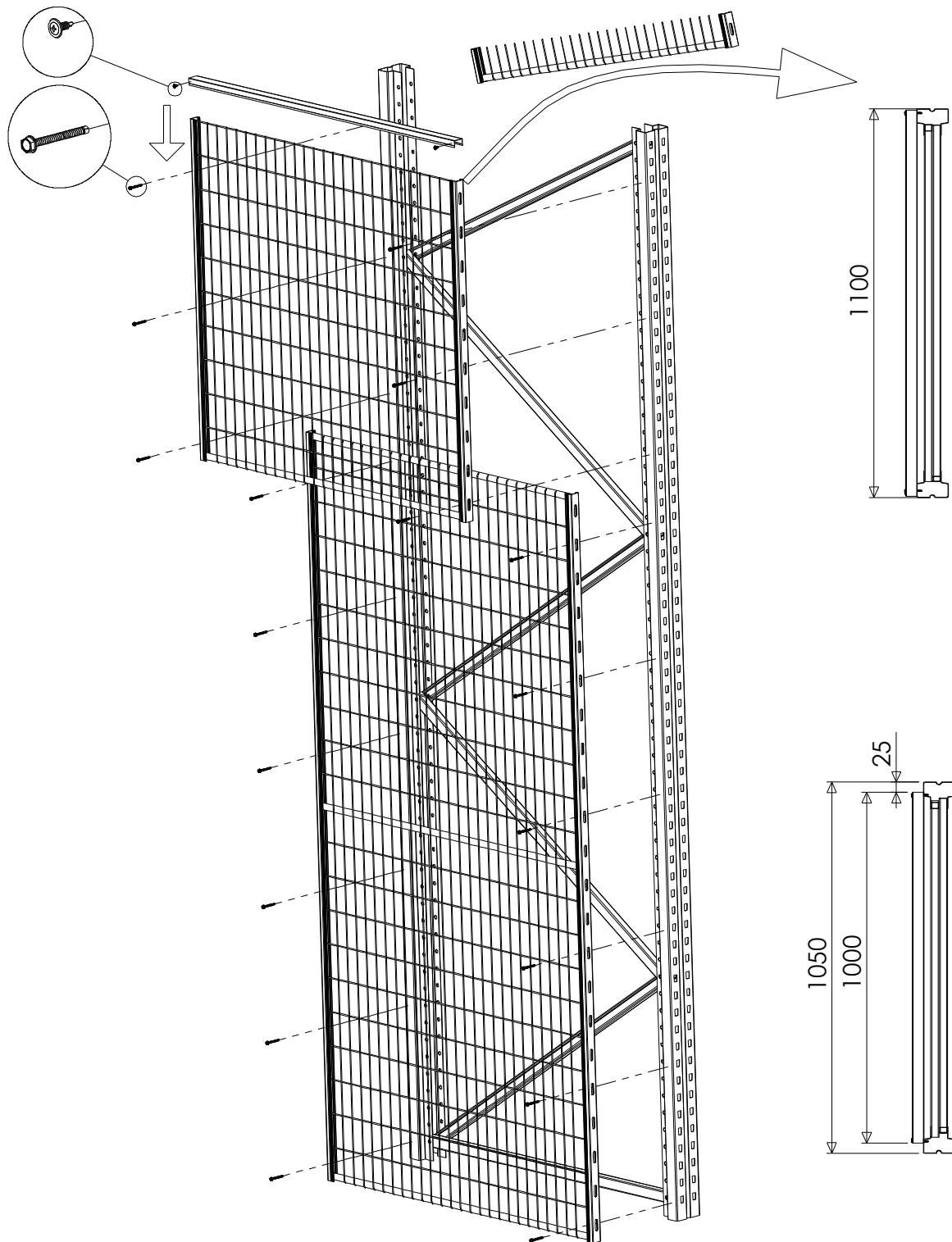

Purchase form

Formulario de pedido

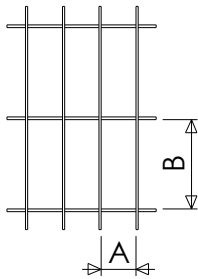

A x B (mm)
38 x 97
18 x 97
18 x 25

	(mm)
C	
D	
E	

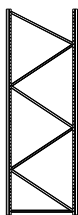

QTY.

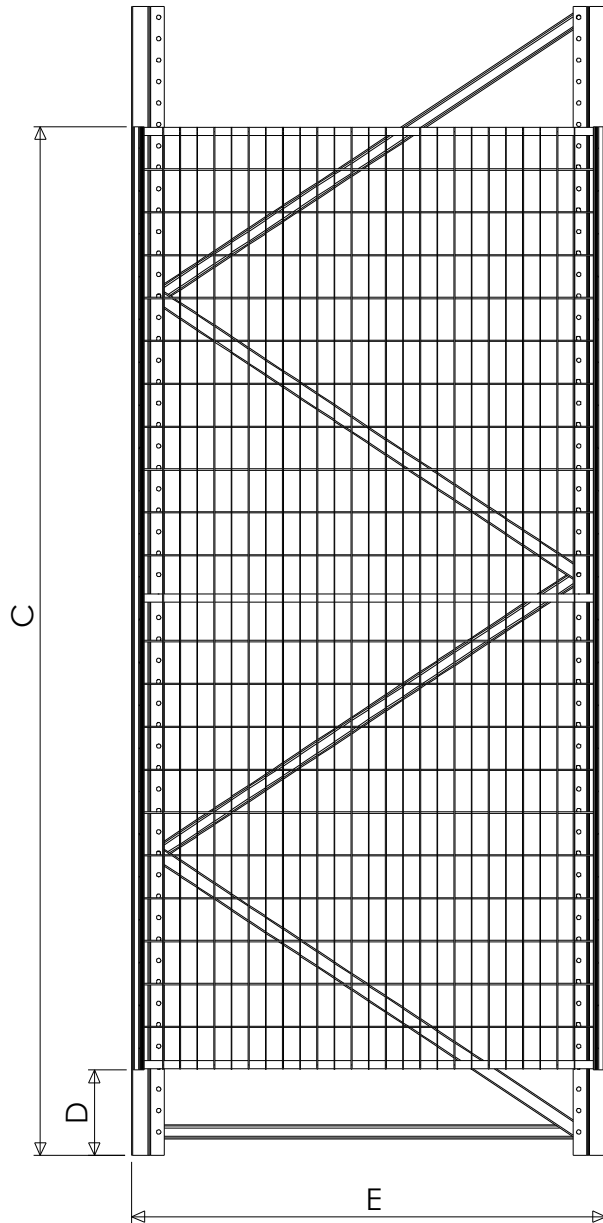



Aisle  
10





# Industrial walls

With focus on stability and short installation times, we have developed an industrial wall, that meets most of the market's needs. The strength lies in stable posts and pre-assembled heavy doors, providing a stable system that can be assembled quickly. The installation costs are often a relatively large proportion of the total cost of a safety net. The customer can save time on site with our warehouse wall, and we reduce the risk that something goes missing or is incorrectly installed. This system also fulfill the demands of the Machinery Directive.

### Mesh element - mesh

- Mesh size 18x97 mm - standard
- Mesh size 18x25 mm - aerosol

### Mesh elements - accessories

- Vertical cutting kit - profile kit for width adjustment
- Horizontal cutting kit - profile kit for height adjustment
- End moulding - edge protectors made of rubber for smaller cut outs in the mesh

### Post

- Single post
- Double posts - used for higher fencing or as reinforcement around bigger doors

### Post assembling - floor

- Anchor bolts - standard
- Chemical fixing
- J-hook - for gratings

### Roof

Roof of mesh modules for cages.

### Door - options

- Single hinged door
- Double hinged door

- Top rail door
- Top rail double door centre locking
- Side hung sliding door without upper rail
- Side hung sliding double door, centre locking, without upper rail

### Door - locking options

- For padlock
- For Eurocylinder
- For Eurocylinder with panic function in the handle
- For Eurocylinder with panic bar
- For Euchner MGB, NZ, TZ
- For Schmersal AZM 200, AZ 16, TVS (Switch for hinges)
- For Siemens 3SE5
- For Trojan 5

### Doors - accessories

- Eurocylinder
- Eurocylinder - key alike
- Door closer

### Surface

As standard we offer our mesh elements galvanized (8-25 µm), doors and posts are powder coated in silver grey (Ral 9006) for use indoors. Also available powder coated in any RAL colour.



# Cerramientos Industriales

Con el enfoque en estabilidad y tiempos de montaje reducidos hemos desarrollado cerramientos industriales que satisfacen la mayoría de las demandas del mercado. La ventaja reside en los puntales fuertes y las puertas pre-montadas de gran estabilidad, lo cual se traduce en cortos tiempos de montaje y un sistema bien robusto. Los tiempos de montaje son con frecuencia gran parte del costo total de un cerramiento de seguridad. El cliente puede hacer ahorros significativos con nuestros cerramientos industriales, y nosotros reducimos el riesgo de que falte algo o quede instalado en forma incorrecta. Este sistema cumple además con las exigencias de seguridad para máquinas

### Elementos de rejilla - Dimensión de celdas de malla

- Dimensión 18x97 mm - Estandar
- Dimensión 18x25 mm - Almacenamiento de aerosoles

### Elementos de rejilla - Accesorios

- Corte vertical - Kit de perfiles para ajustar el ancho
- Corte horizontal - Kit de perfiles para ajustar el alto
- Listón de acabado - perfil de goma para cortes menores en la rejilla

### Puntales

- Puntales single
- Puntales dobles - cuando se requiere mayor altura o para refuerzo alrededor de puertas grandes.

### Fijación de puntales - suelo/piso

- Pernos de anclaje- estandar
- Tuerca fijación química
- Ganchos - J- pisos de enrejados metálicos

### Techo

Techo con elementos de rejilla para jaulas

### Puertas - alternativas

- Puerta de una hoja
- Puerta de dos hojas

- Puerta corredera con riel superior
- Puerta corredera doble con cierre de centro con riel superior
- Puerta corredera de fijación lateral sin riel
- Puerta corredera de fijación lateral doble, cierre de centro sin riel superior

### Opciones de cierre de puertas

- Para candados
- Para Eurocylinder
- Para Eurocylinder con función anti-pánico en las manillas
- Para Eurocylinder con barra anti-pánico
- Para Euchner MGB, NZ, TZ
- Para Schmersal AZM 200, AZ 16, TVS (Interruptor)
- Para Siemens 3SE5
- Para Trojan 5

### Puerta - Accesorios

- Eurocylinder
- Eurocylinder - serie de cerradura idéntica
- Cierre mecánico de puerta

### Acabado

Como estandar las partes están galvanizadas (8-25µm) para uso interior. Los puntales y las puertas están cubiertas con pintura al polvo en el color RAL- 9006. Nuestros productos también se pueden disponer en cada color RAL



## Posts

## Puntales

Standard heights are 1150, 2250 and thereafter in 200 mm steps up to 11050 mm. Floor distance is as standard 50 mm.

Los largos estandar comienzan desde 1150, 2250 y luego en incrementos de 200 mm hasta los 11050 mm. La distancia al suelo/piso es como estandar 50 mm.

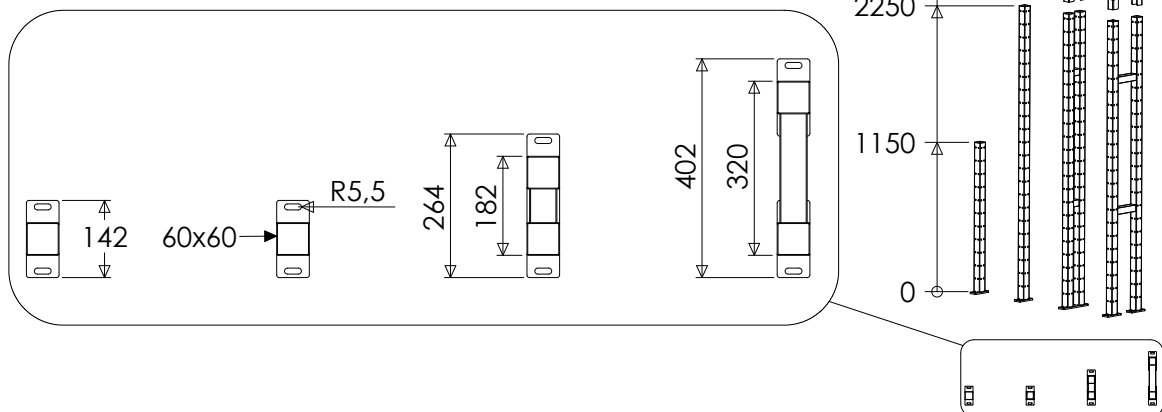

Mesh element

Elementos de rejilla

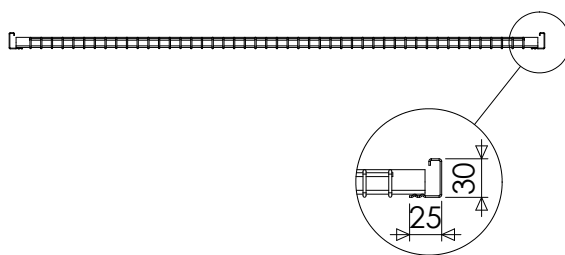
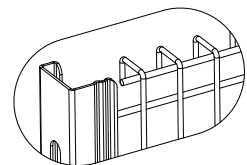
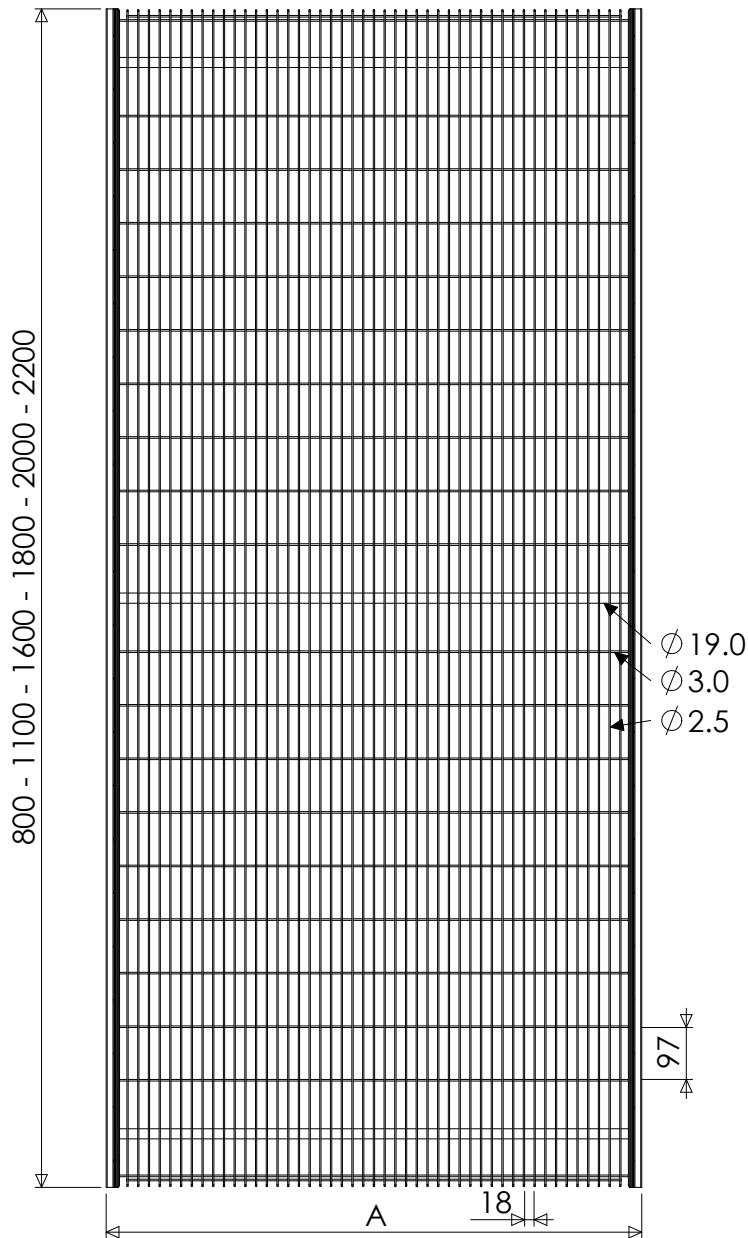

A
200
300
400
500
600
700
800
900
1000
1100
1200
1500

Industrial wall

Cerramiento industrial

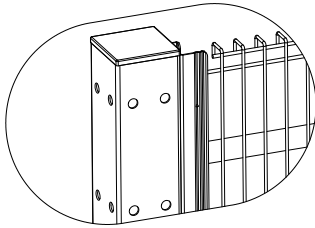

A (mm)	B (mm)
1400	200
1800	300
2000	400
2200	500
2400	600
	700
	800
	900
	1000
	1100
	1200
	1500

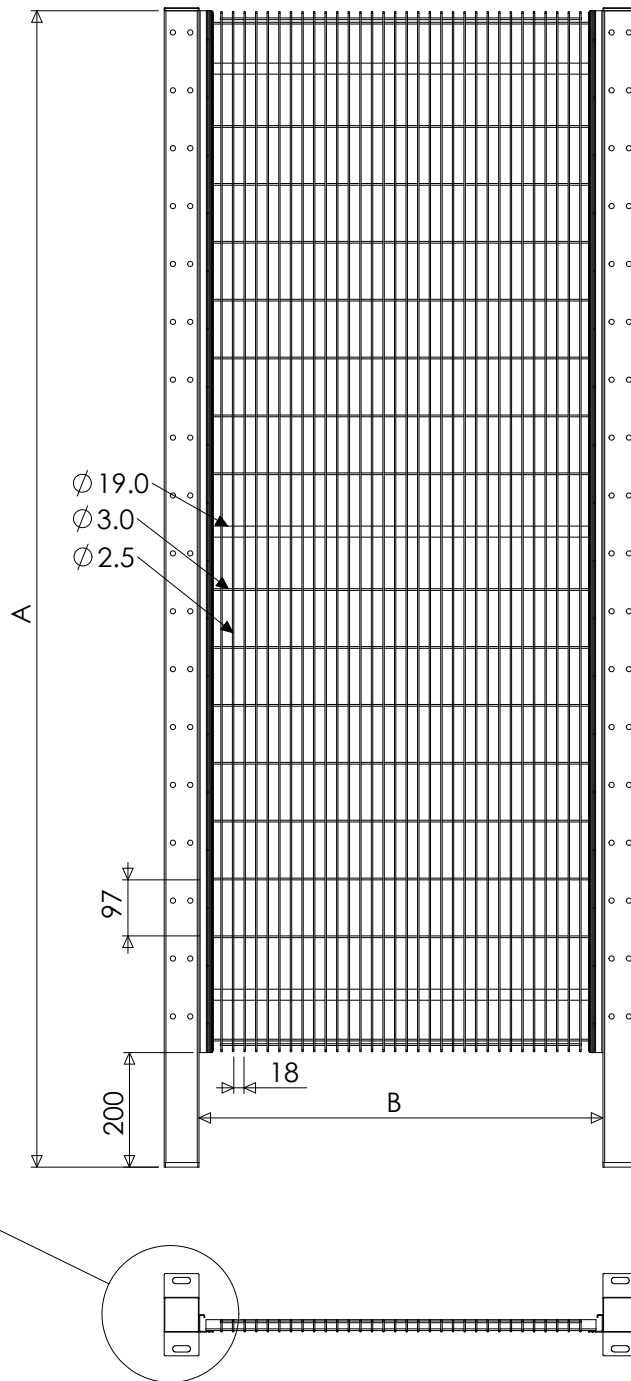
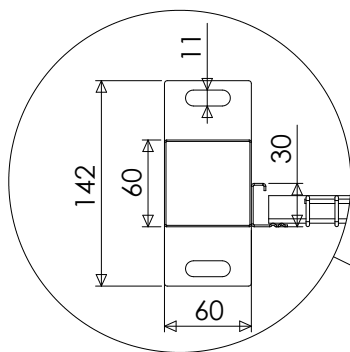

Quick fixing release

Fijaciones rápidas

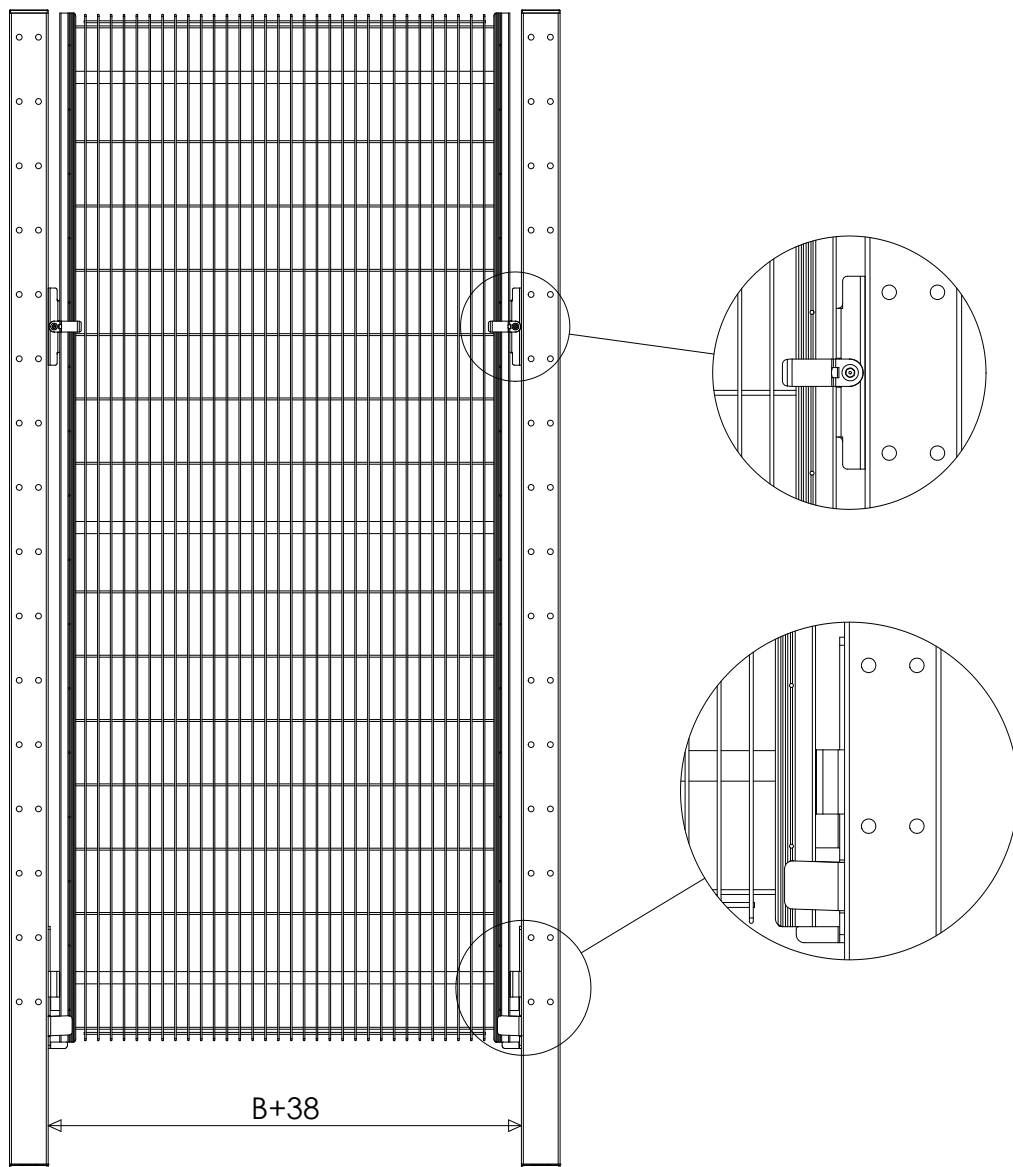

## Safety distances

## Distancias de seguridad

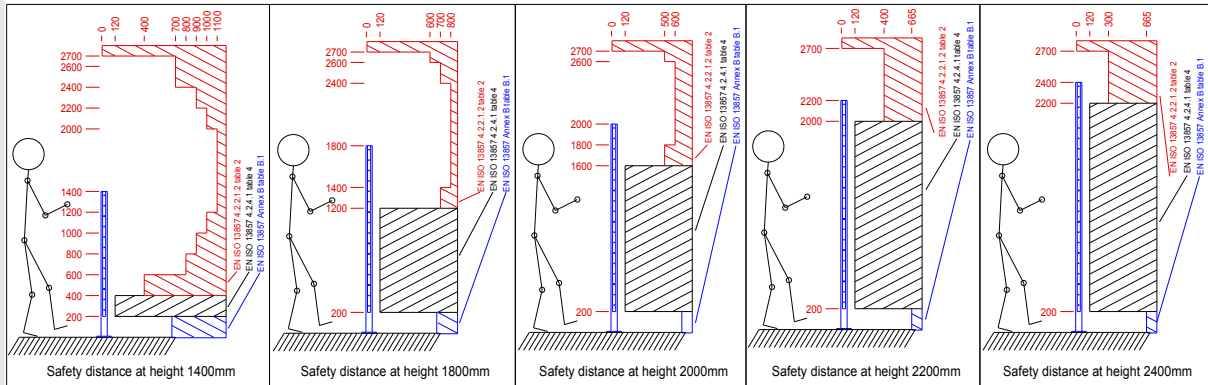



Material door

Material puerta

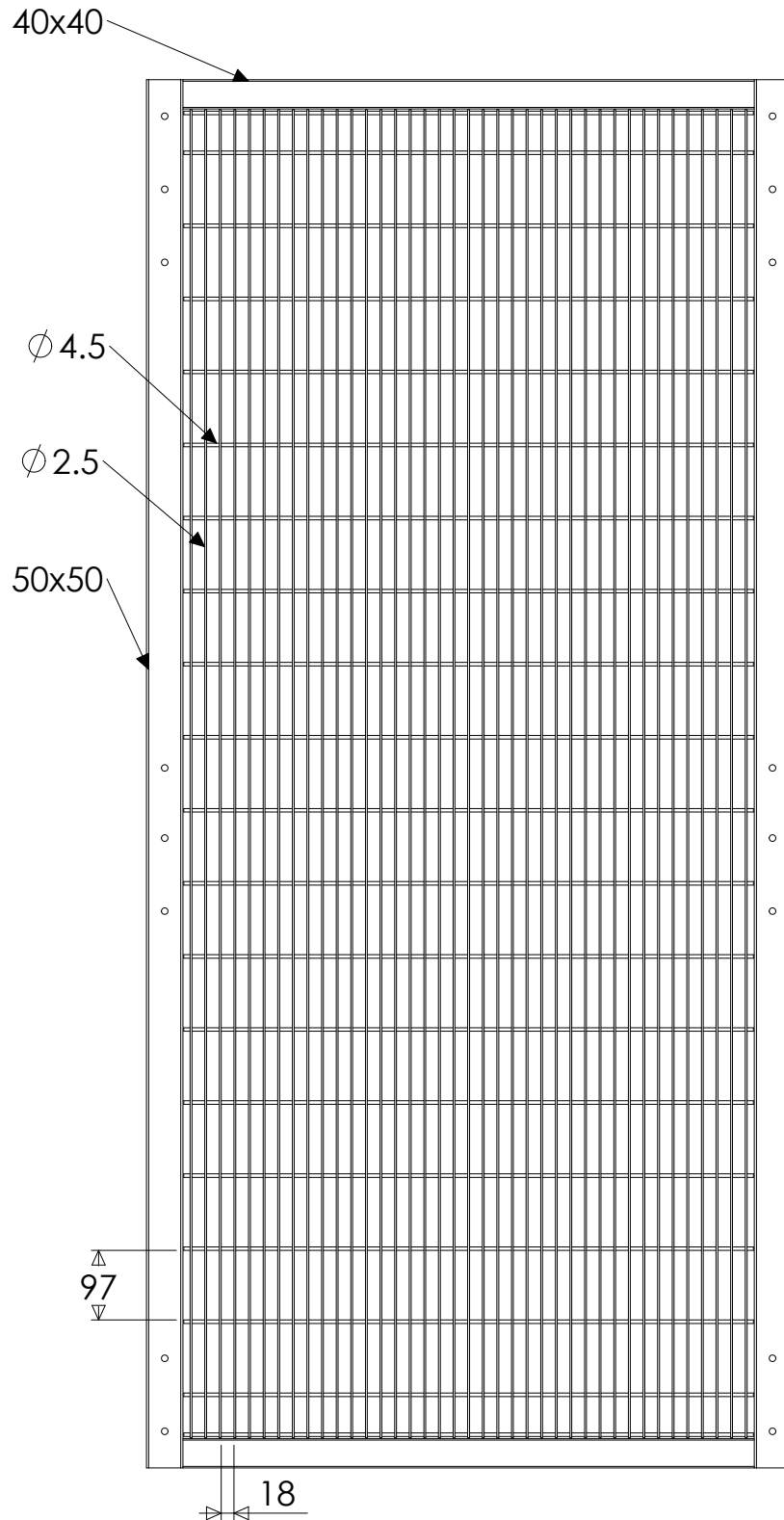

## Door options

## Alternativas de puertas

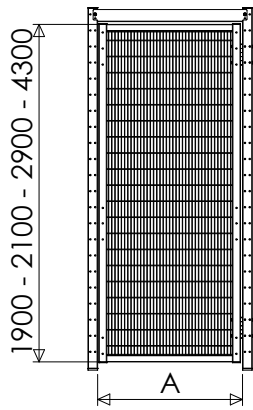

A
700*
800*
900
1000*
1100*
1200
1500

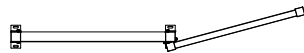

\* = Only available in heights up to 2200mm.

\* = Sólo disponible en altos hasta 2200mm

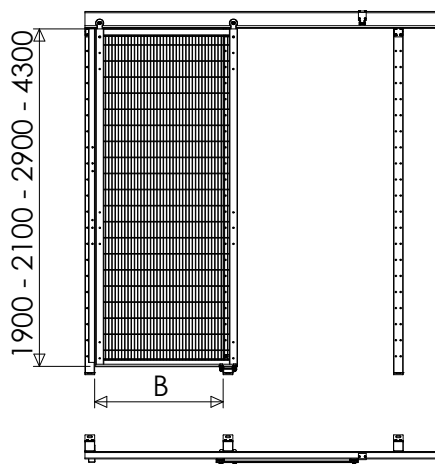

B
800
1100
1400
2300
2900

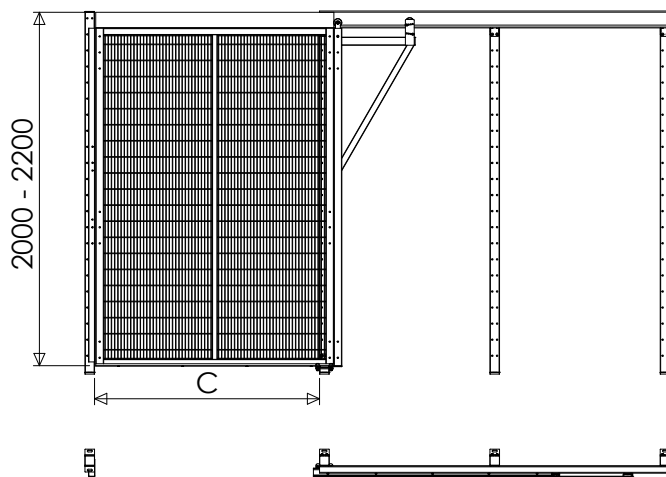

C
800
1400

Door options

Alternativas de puertas

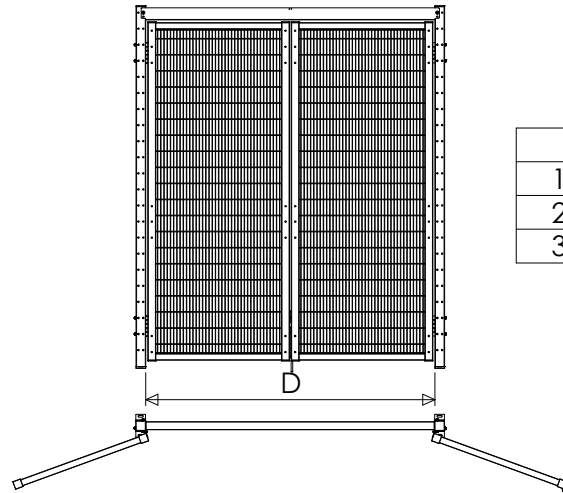

D
1800
2400
3000

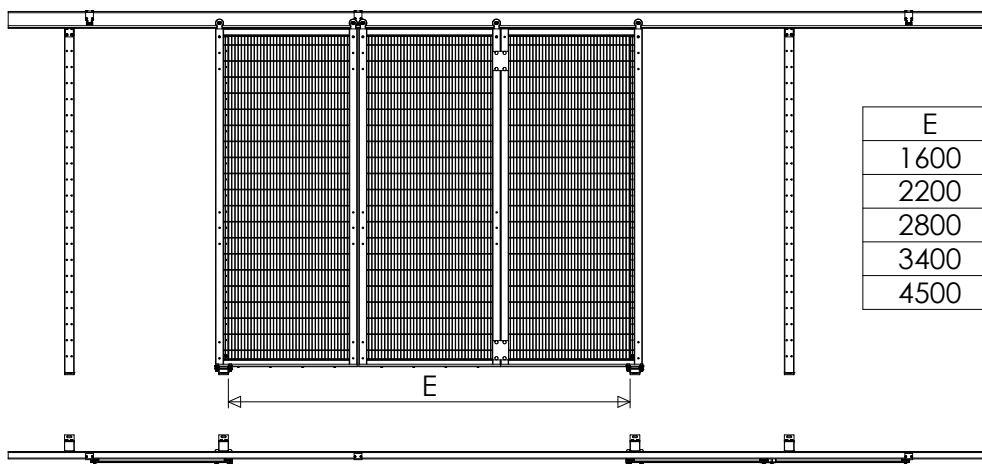

E
1600
2200
2800
3400
4500

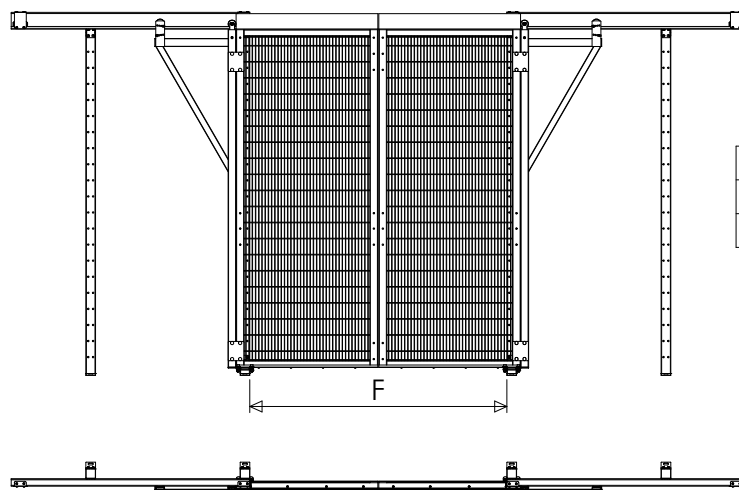

F
2200
2800

### Lock options

### Alternativas de cerraduras



Pad lock plates  
Fits both hinged- and sliding doors.

Puerta con cerradura para candado  
Para puertas correderas y batientes.



Cylinder locked door  
Fits both hinged- and sliding doors.

Puerta con cerradura de cilindro  
Para puertas correderas y batientes.



Door with approved panic lock. A door with panic lock can always be opened from the inside even when it is locked. Not working for sliding doors.

Puerta de emergencia con cerradura anti-pánico aprobada. Esta puerta también se puede abrir desde adentro aún cuando esté cerrada. No para correderas.



Door with approved panic bar and lock. A door with panic bar can always be opened from the inside even if it is locked. Not working for sliding doors.

Puerta con barra anti-pánico.  
Esta puerta se puede abrir desde adentro aún cuando esté cerrada.  
No para puertas correderas.

## Lock options

### Alternativas de cerraduras

Cane bolt prepared for:  
Cierre de pasador apta para:

- Schmersal AZ 16
- Euchner NZ
- Euchner TZ
- Siemens 3SE5
- Trojan 5



Schmersal AZM200



Euchner MGB



Mounting plate for knobs  
Placa de fijado para salida de emergencia



Walls

Cerramientos

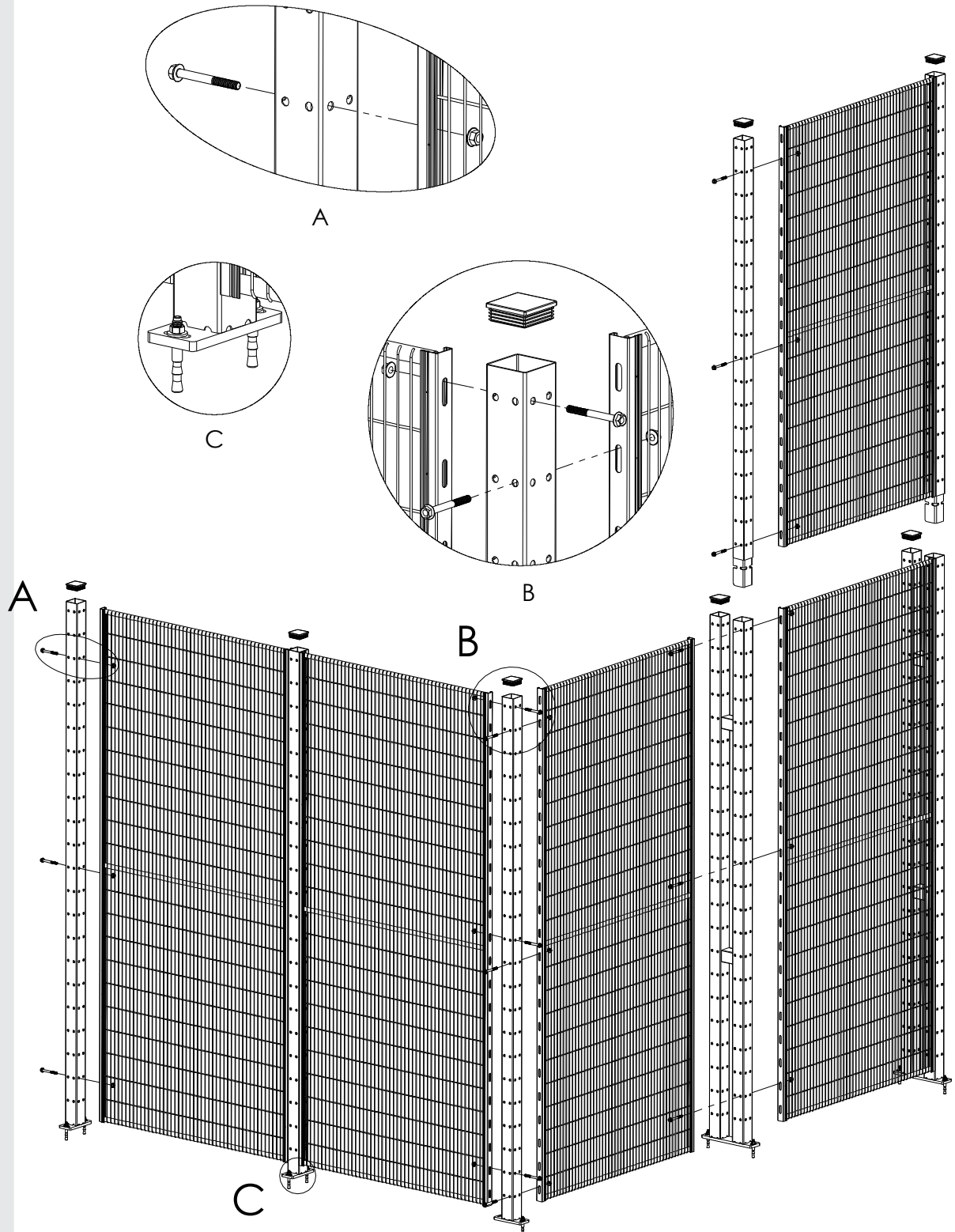

Wall fixing

Fijación de cerramientos

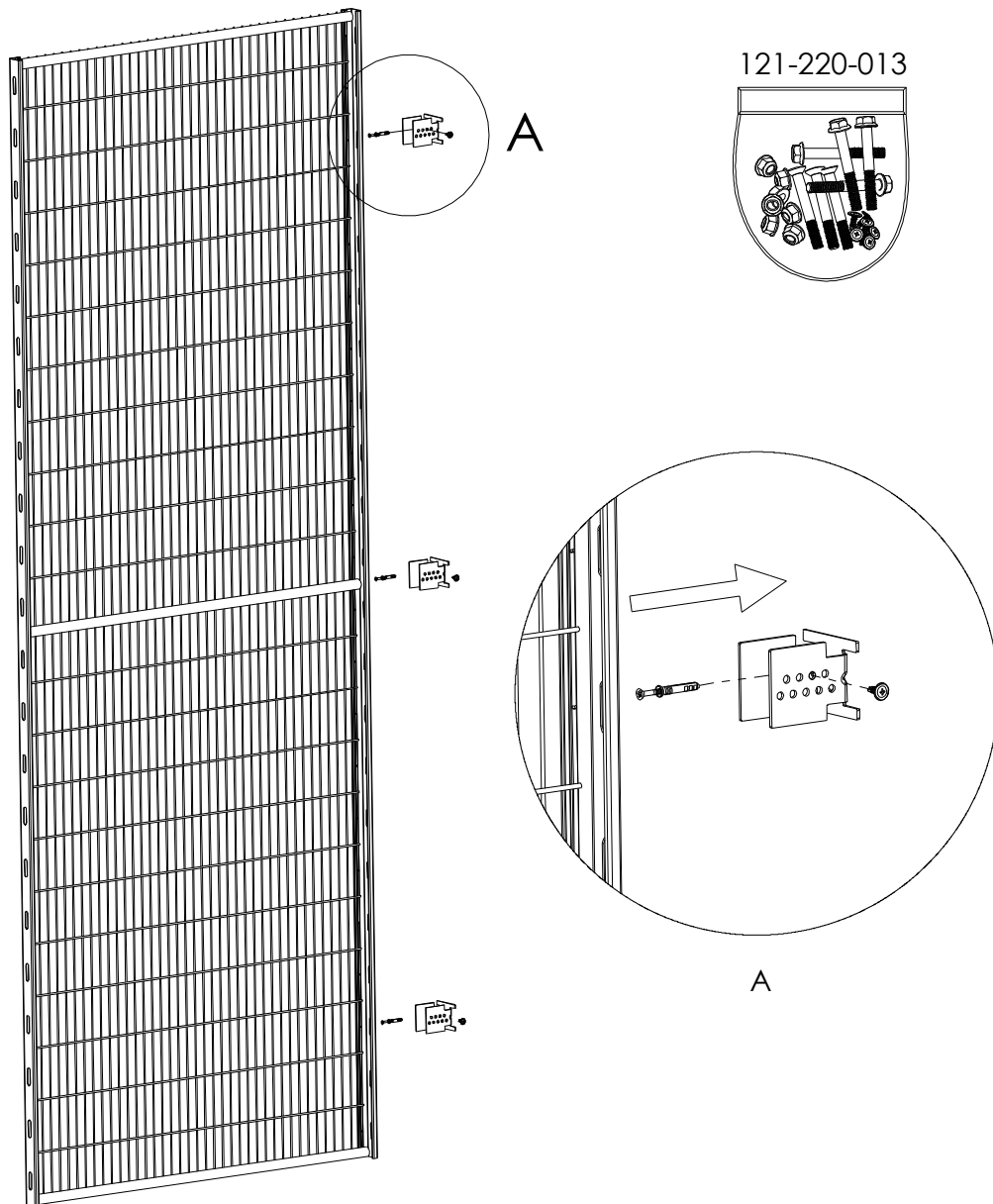

Quick fixing release

Fijaciones rápidas

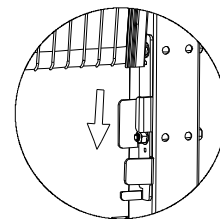
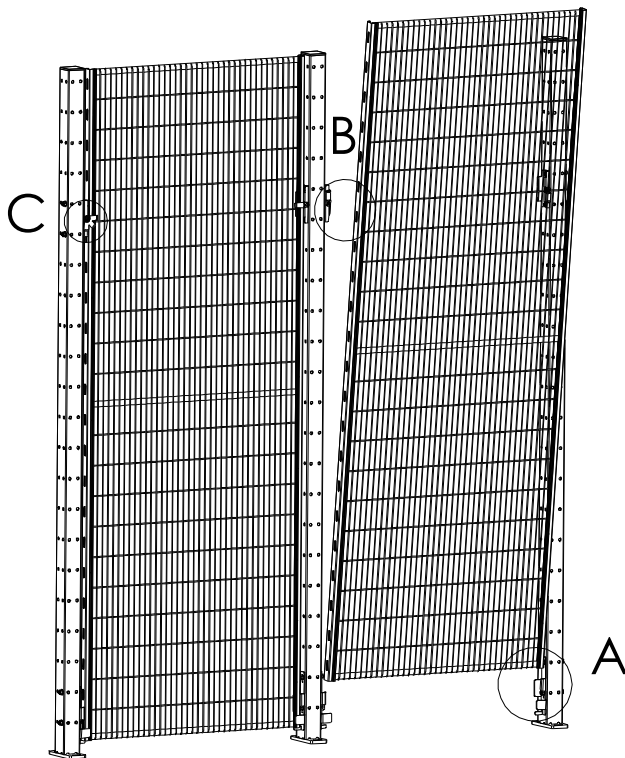
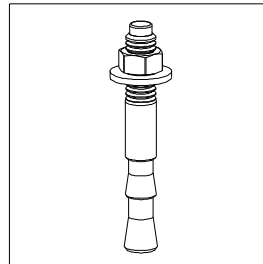
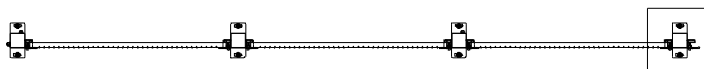
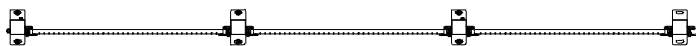
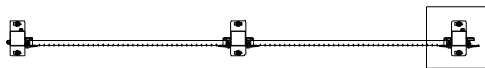

A

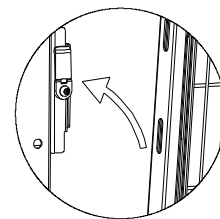

B

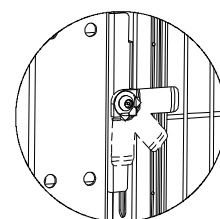

C



Quick fixing release

Fijaciones rápidas

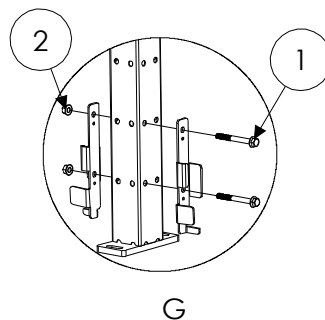
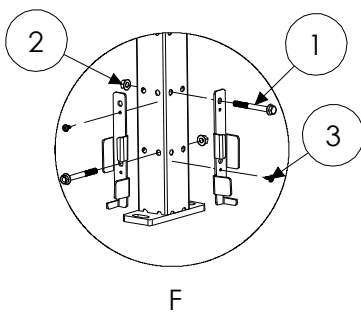
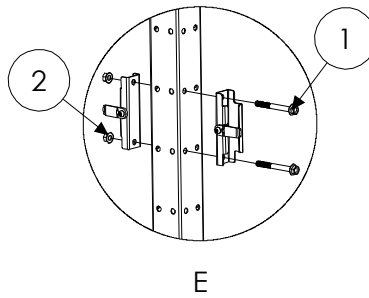
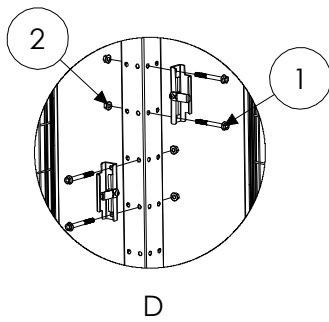
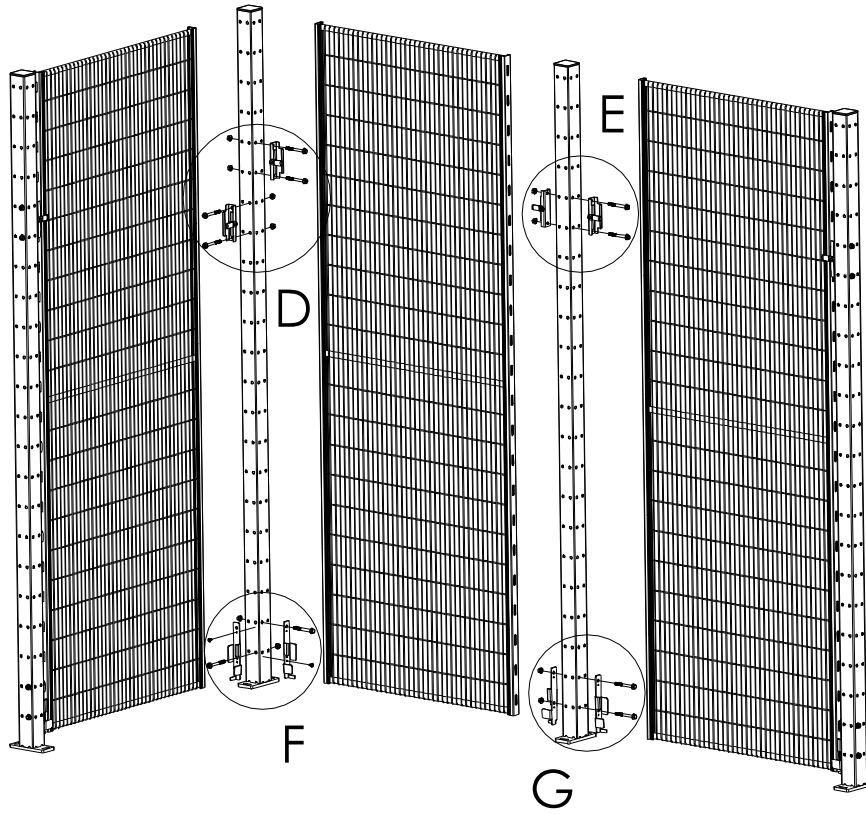

Vertical cutting

Corte vertical

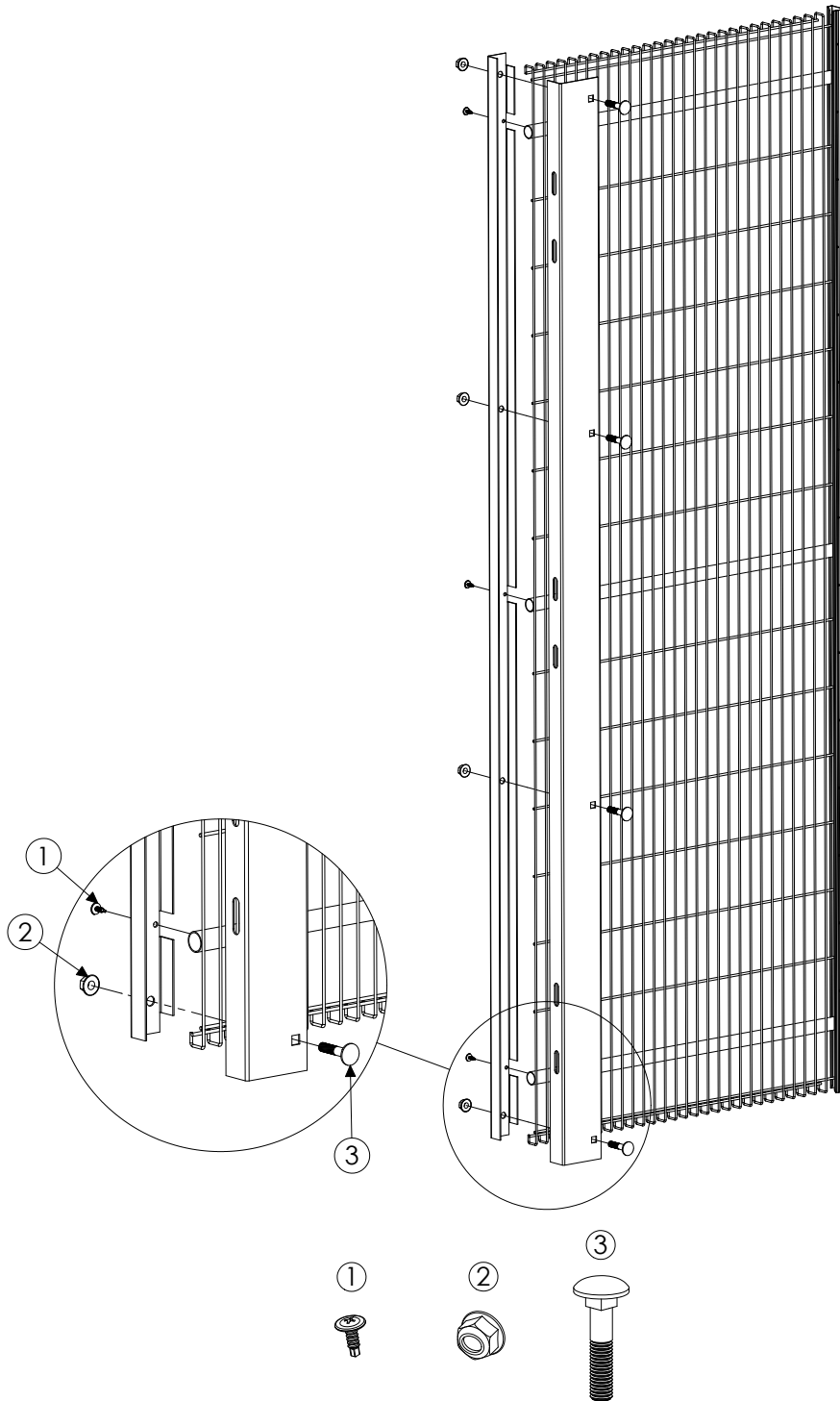

Horizontal cutting

Corte horizontal

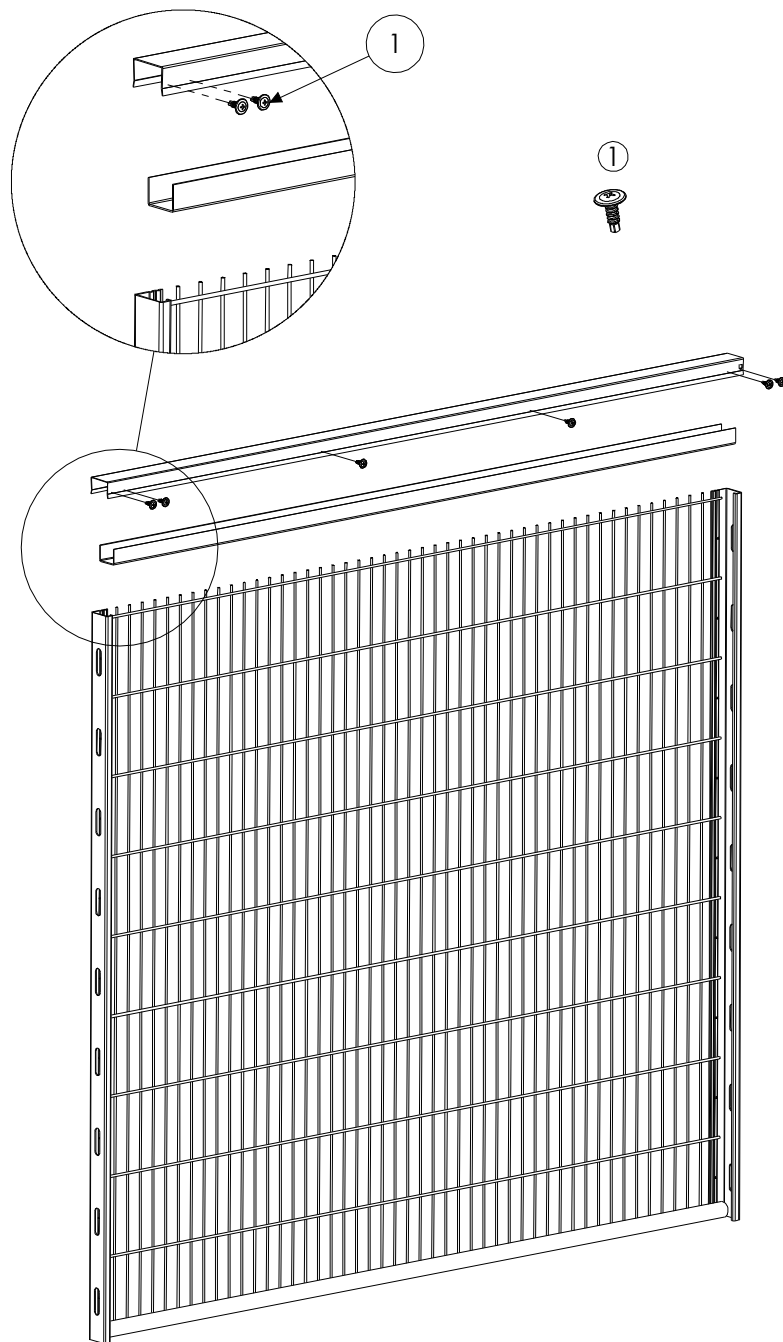

Roof

Techo

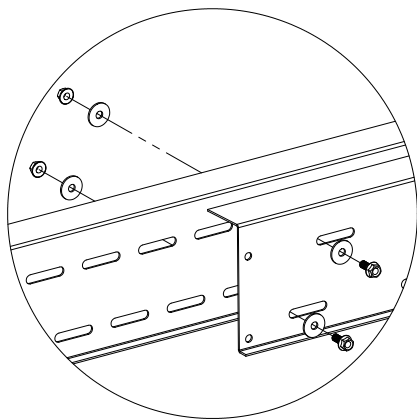
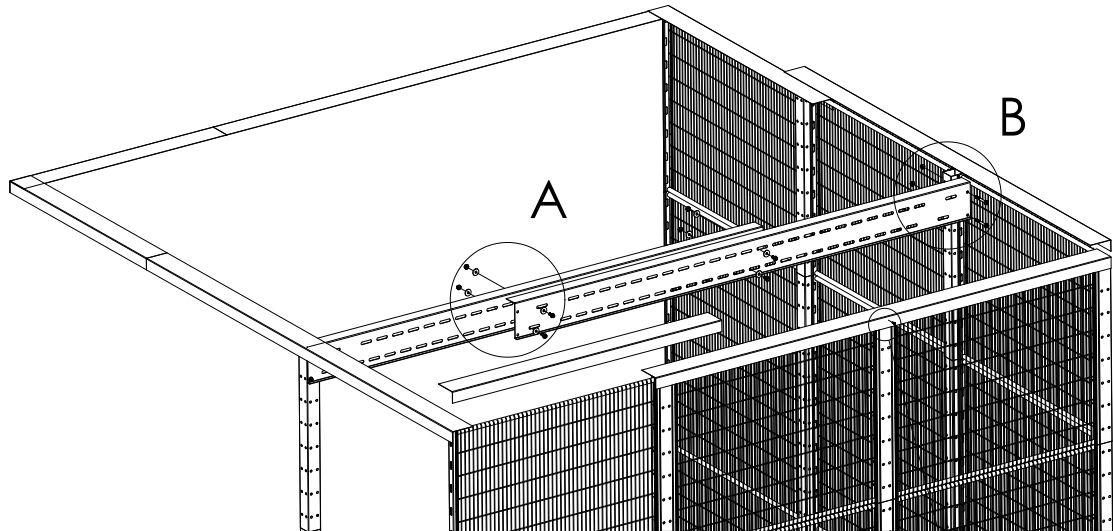

A

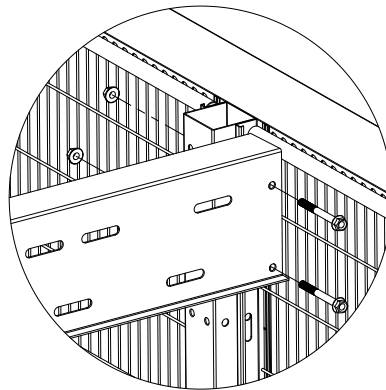

B

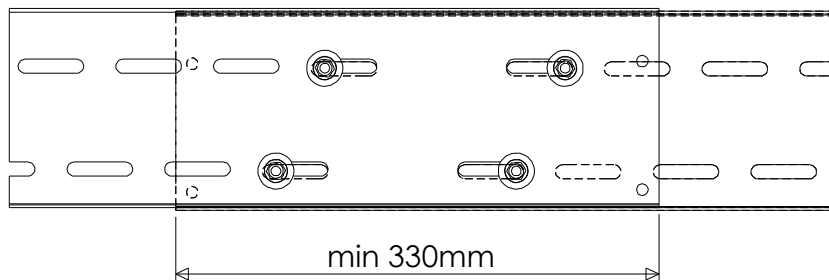
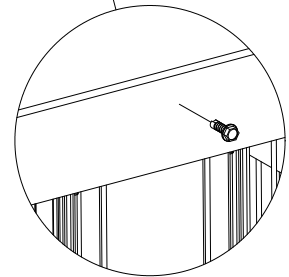

Roof

Techo

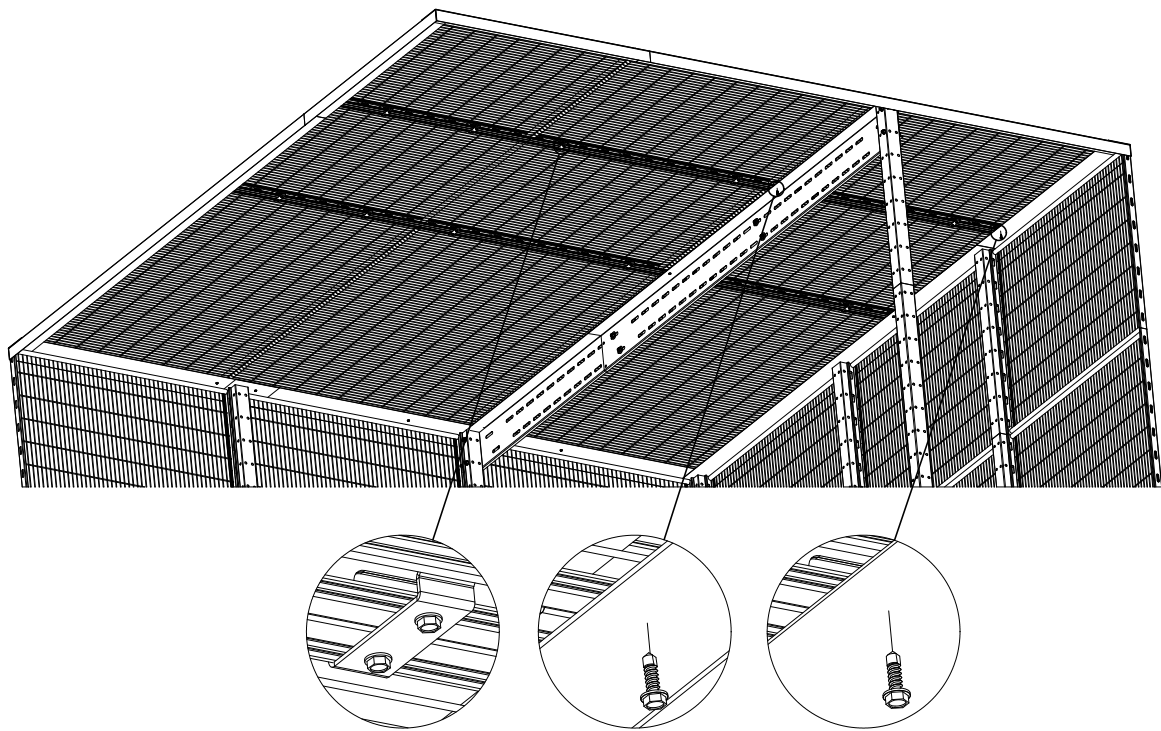
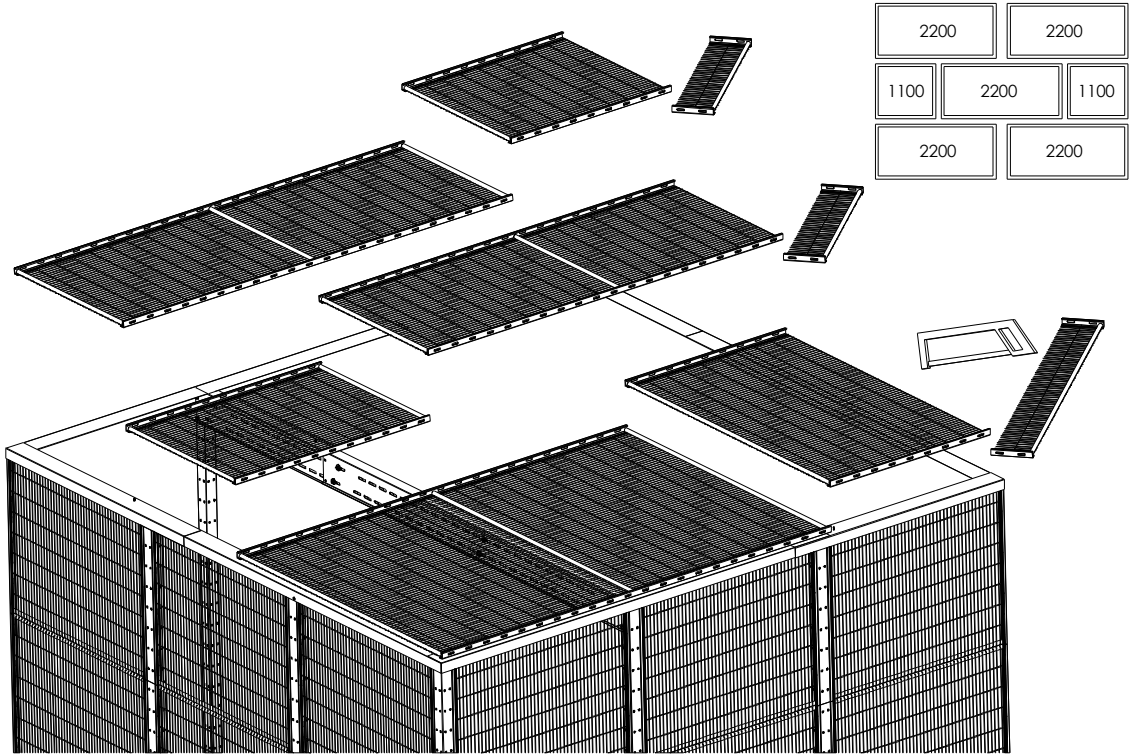

Single hinged door for euro cylinder

Puerta de una hoja para euro cilindro

223-220-001

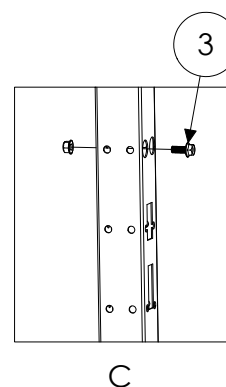
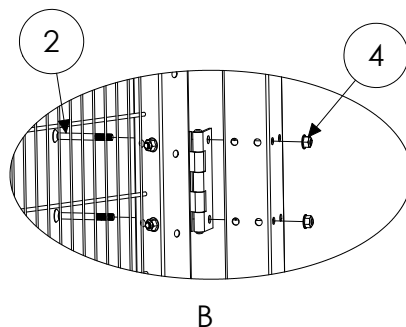
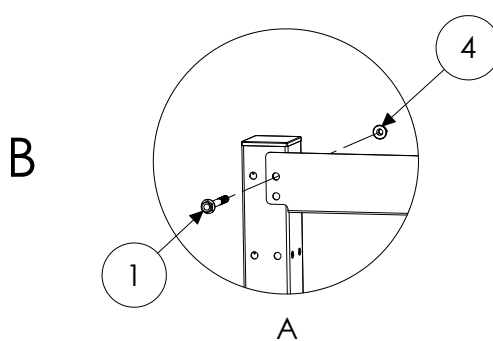
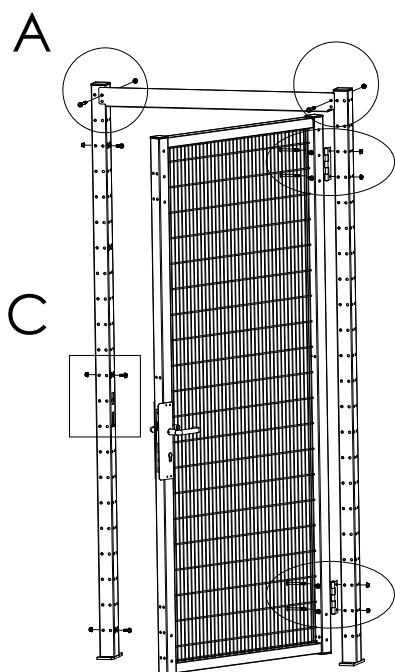
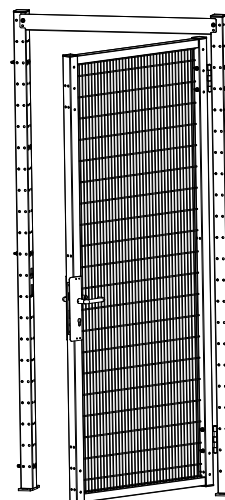
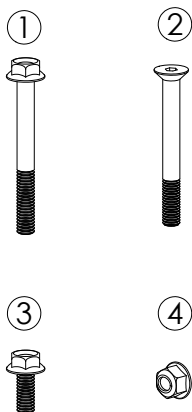
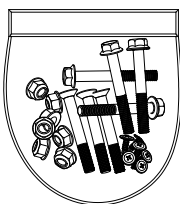

Single hinged door

Puerta de una hoja

223-220-008

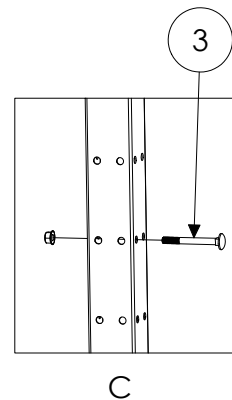
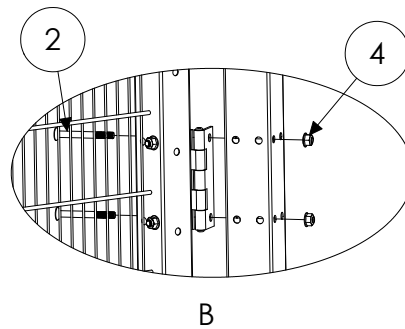
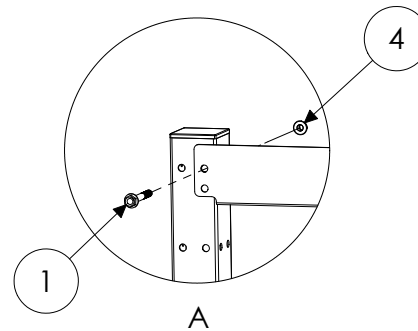
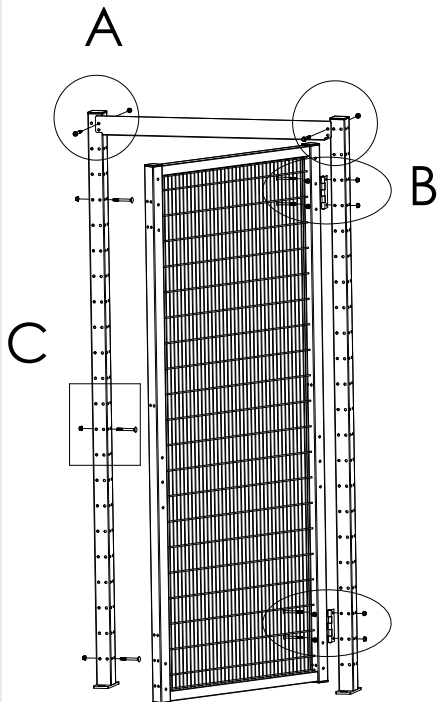
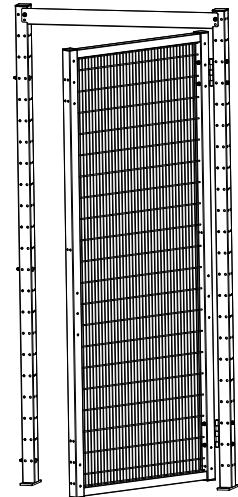
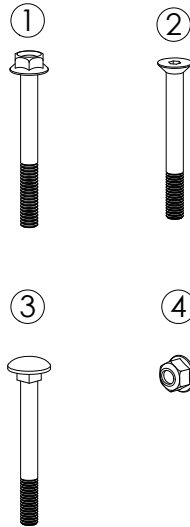
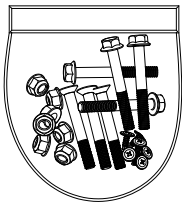

Escape door

Puerta de emergencia

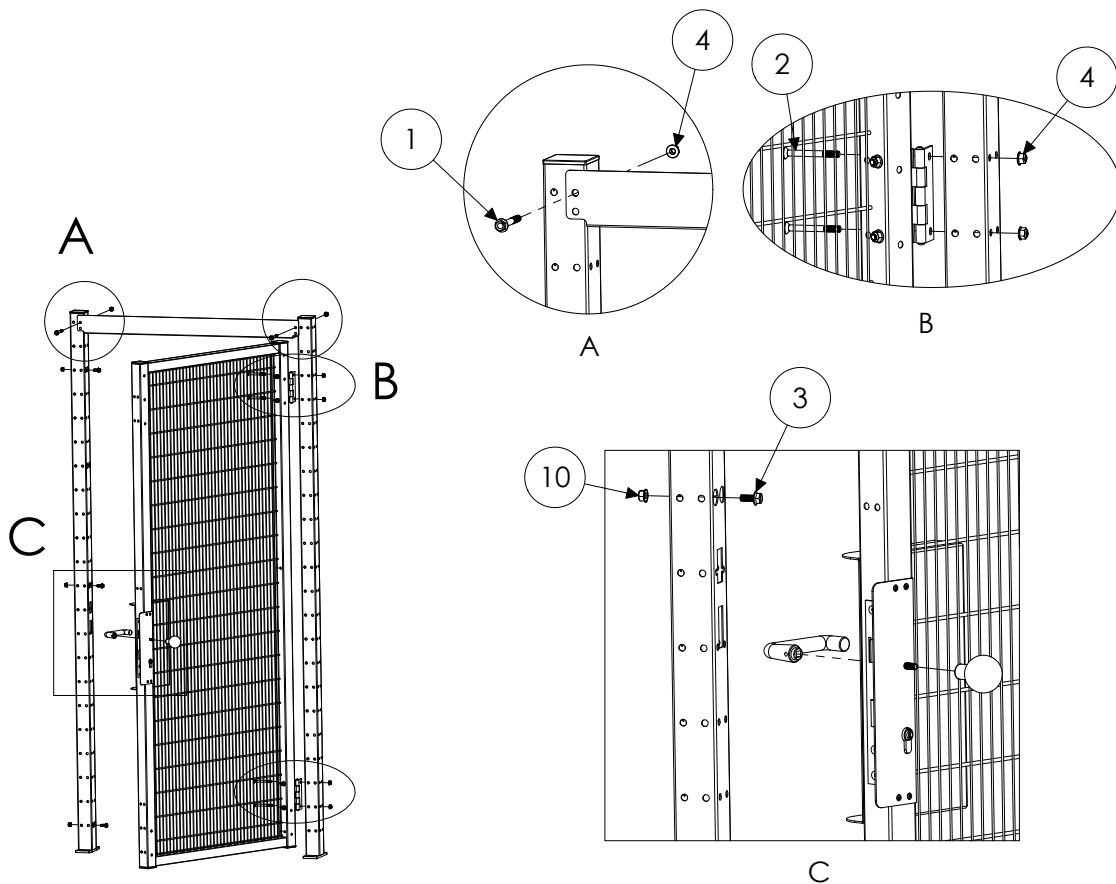
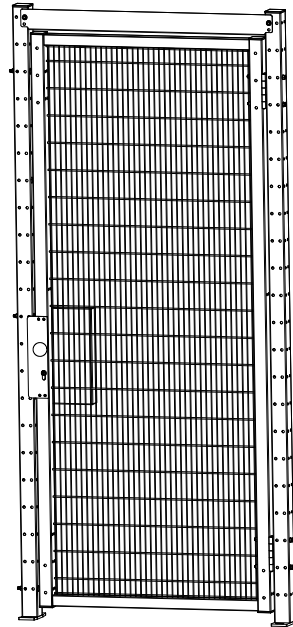
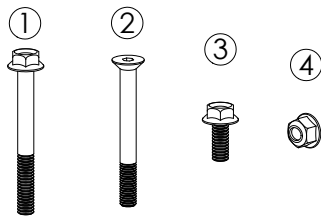
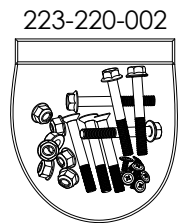



Escape door with push bar

Puerta de emergencia con barra anti-pánico

223-220-004

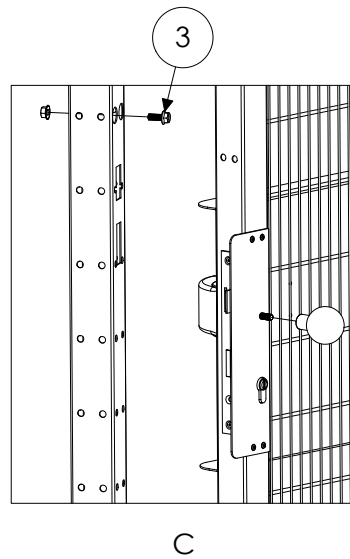
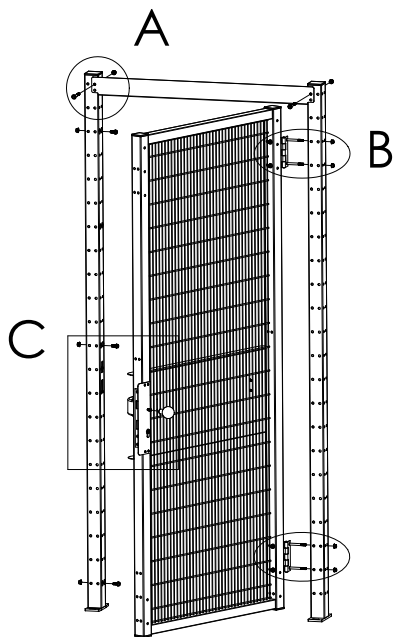
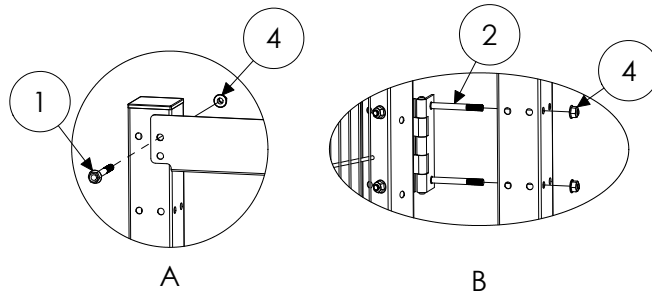
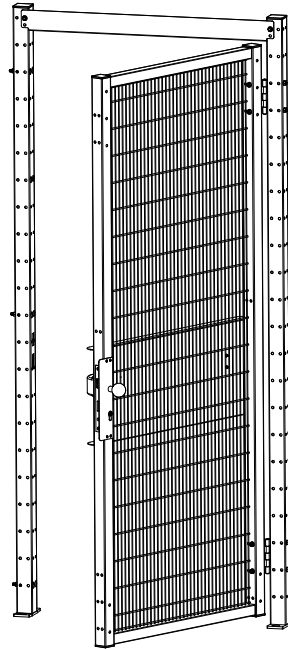
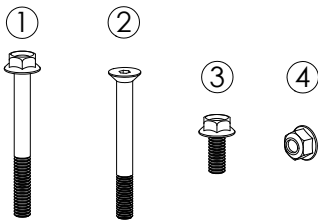
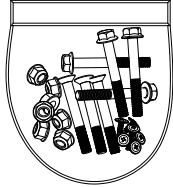

Single hinged door H 3000-4400

Puerta de una hoja H 3000-4400

223-440-002

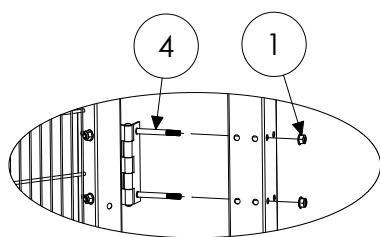
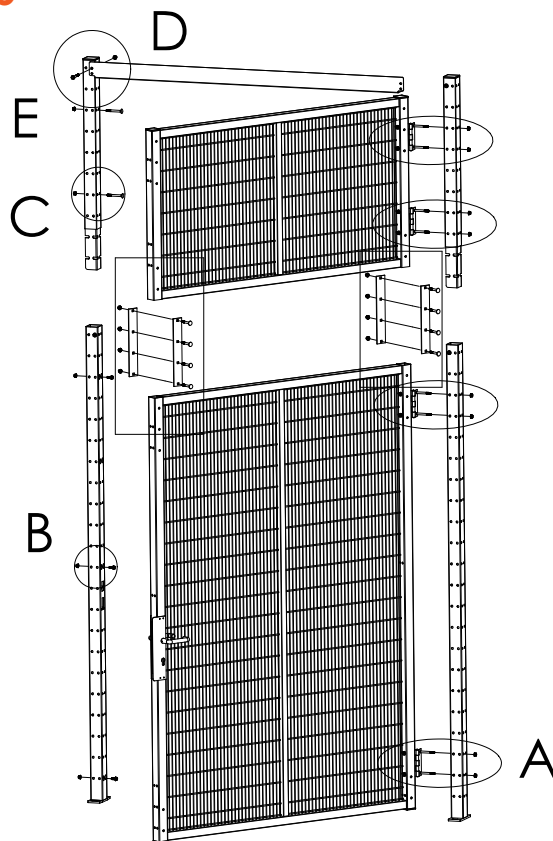
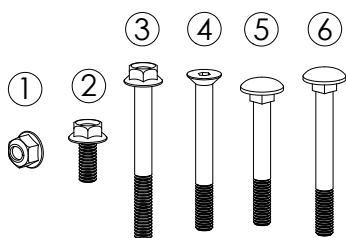
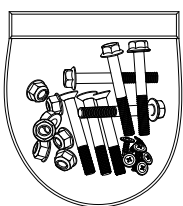

A

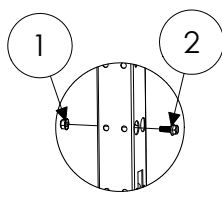

B

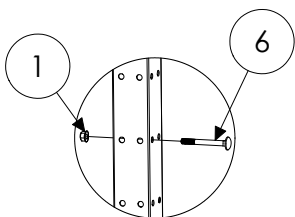

C

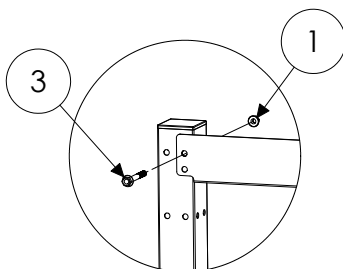

D

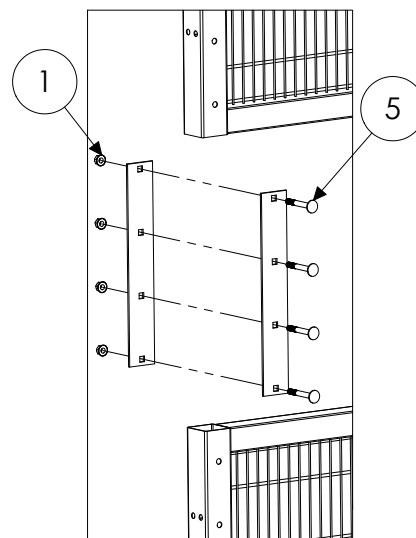

E

Double hinged door

Puerta de dos hojas

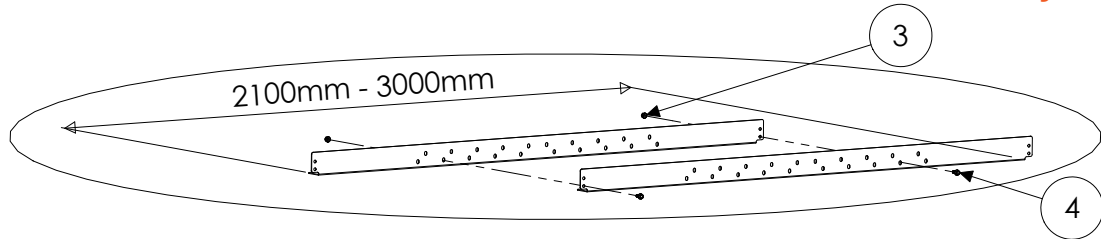

223-220-003

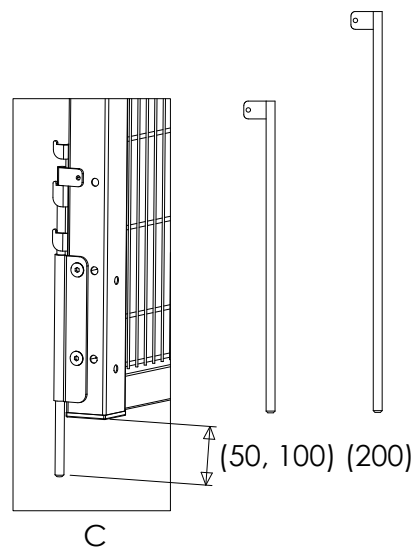
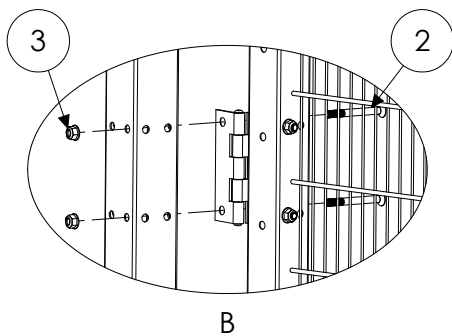
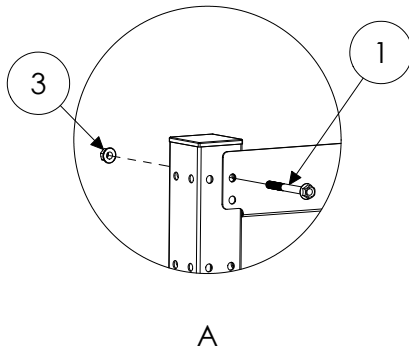
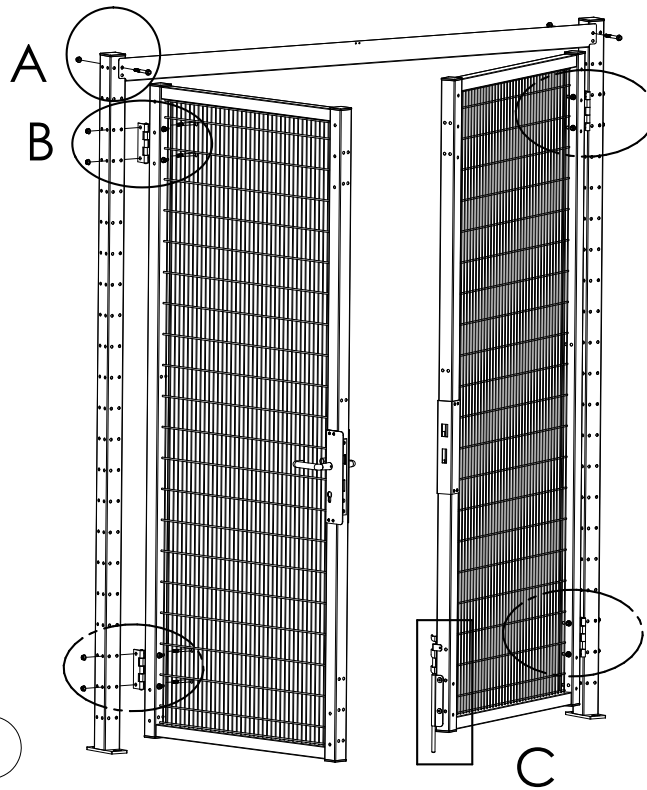
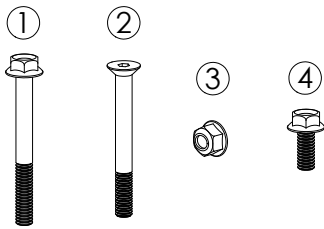
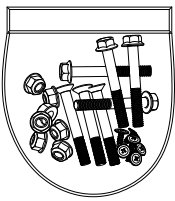

Double hinged door H 3000-4400

Puerta de dos hojas H 3000-4400

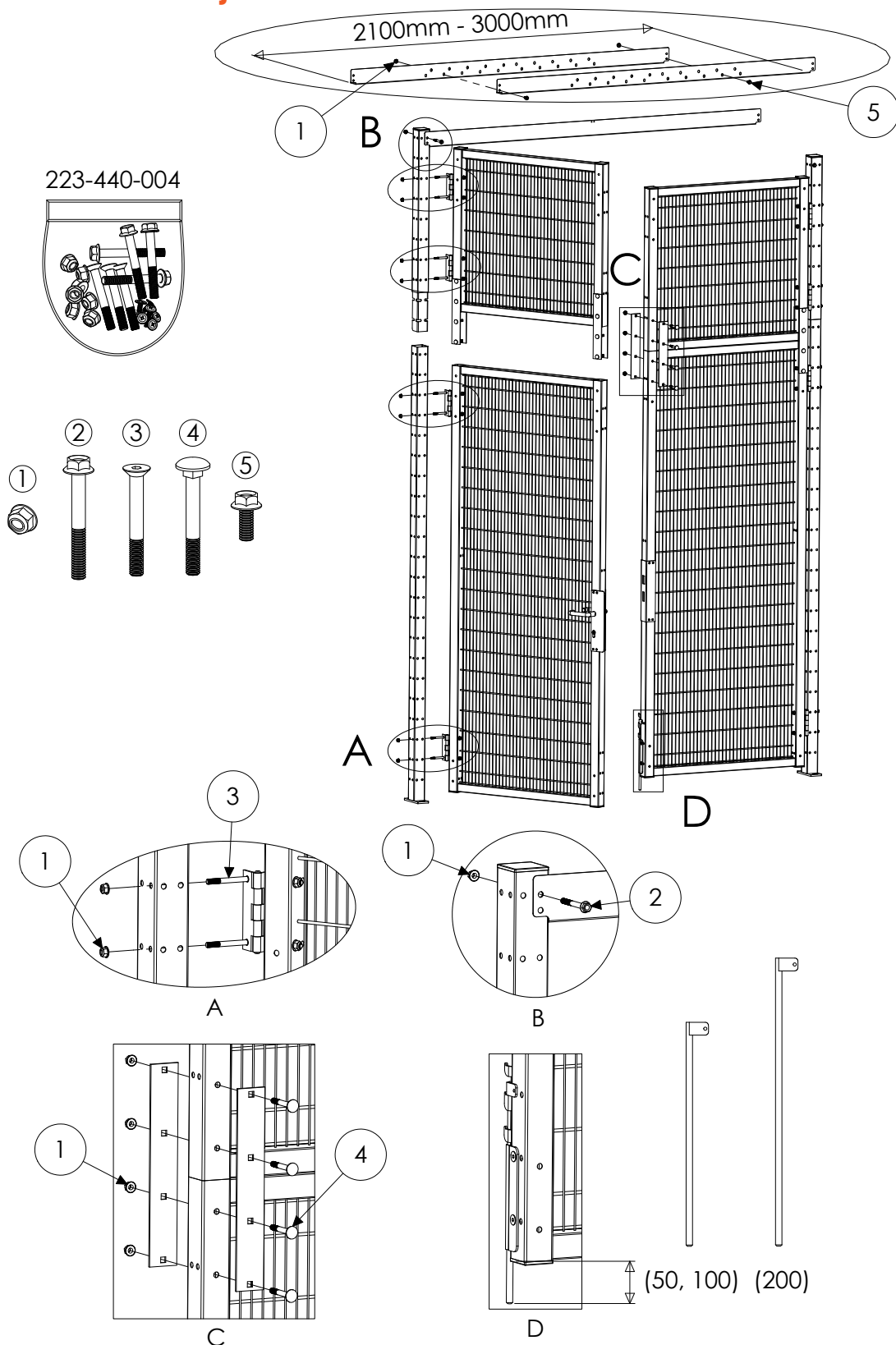

Door support W 3000

Refuerzo para puerta A 3000

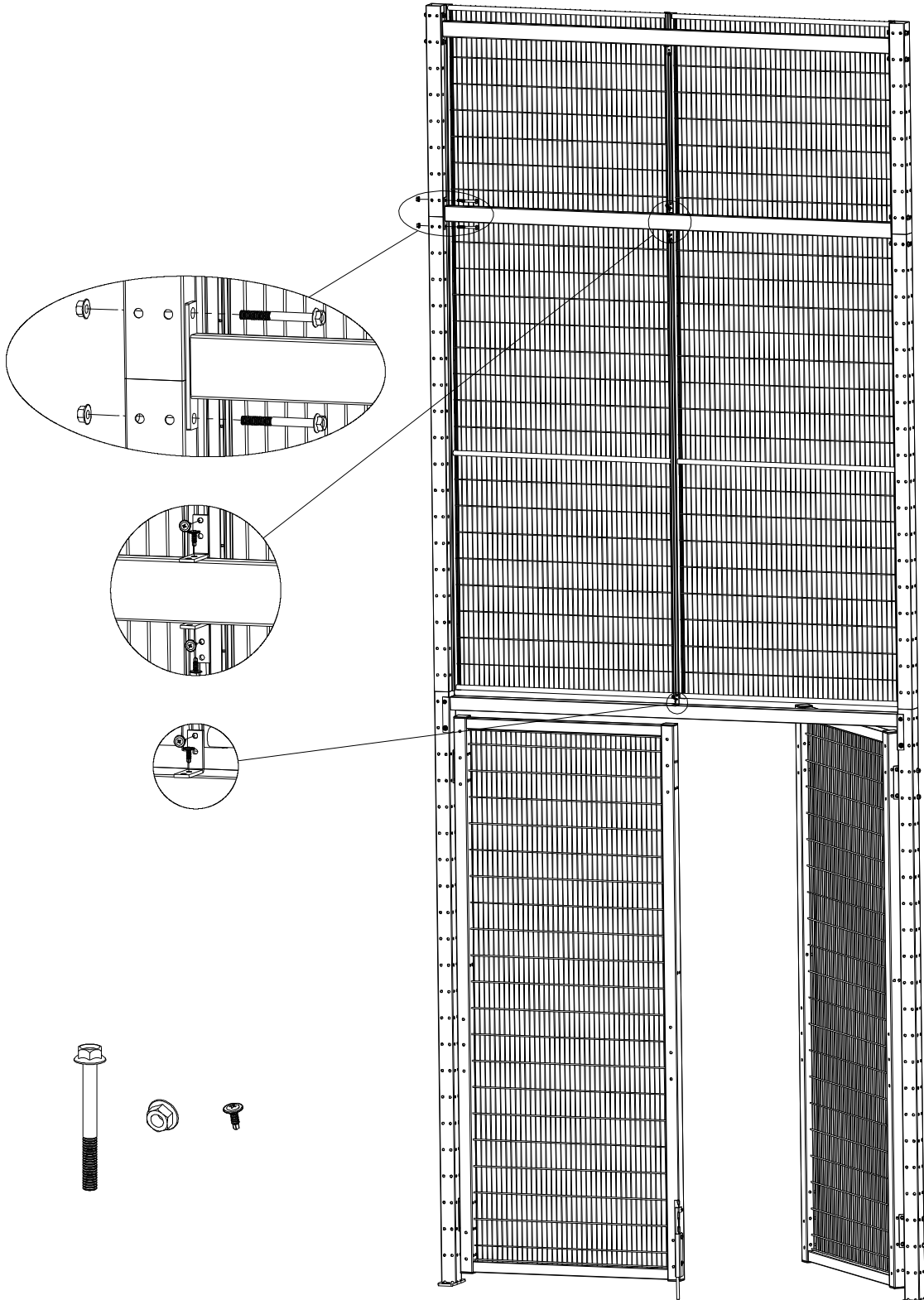

Door closer

Cierre mecánico de puerta

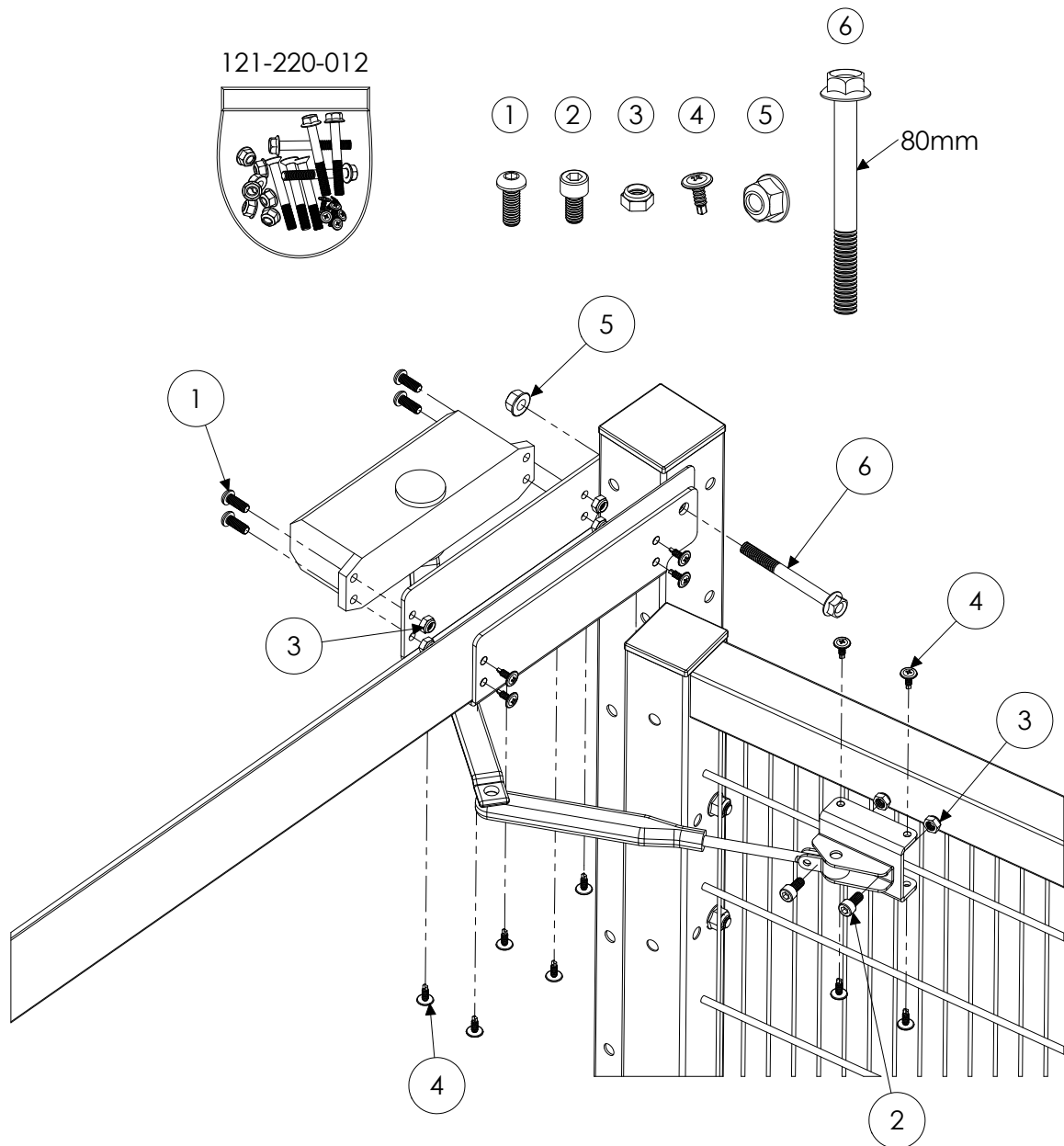

Single sliding door W 800-1400

Puerta corredera de una hoja A 800-1400

243-220-005

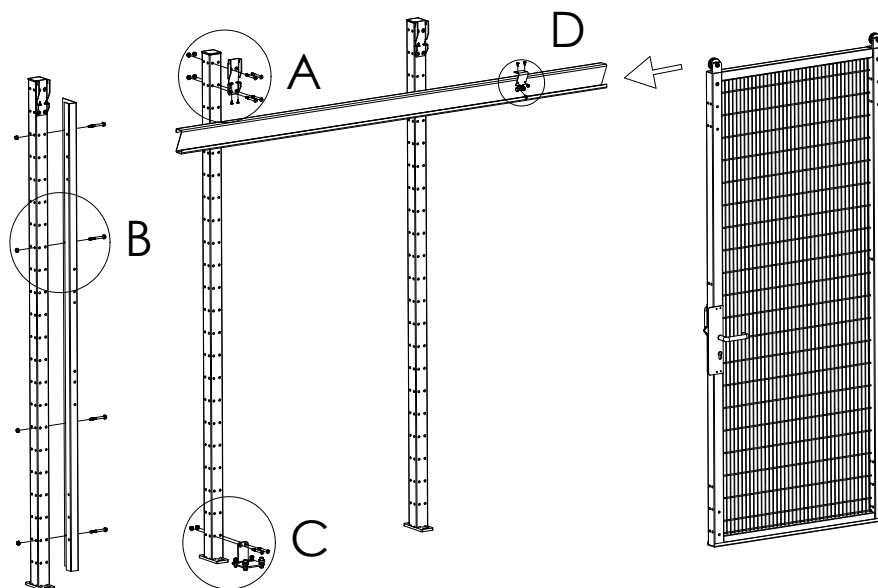
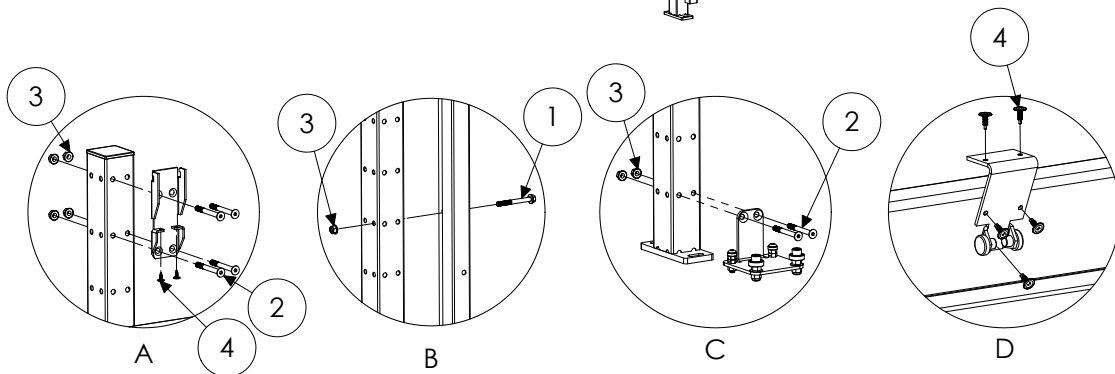
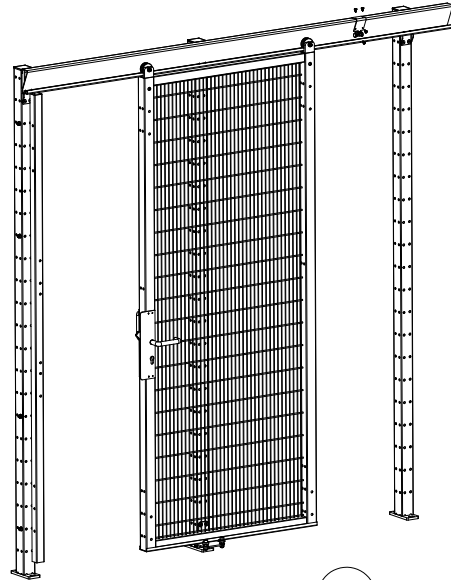
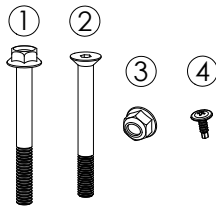
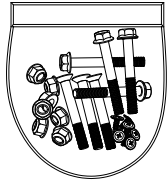

Double sliding door W 1600-2800

Puerta corredera doble A 1600-2800

243-220-009

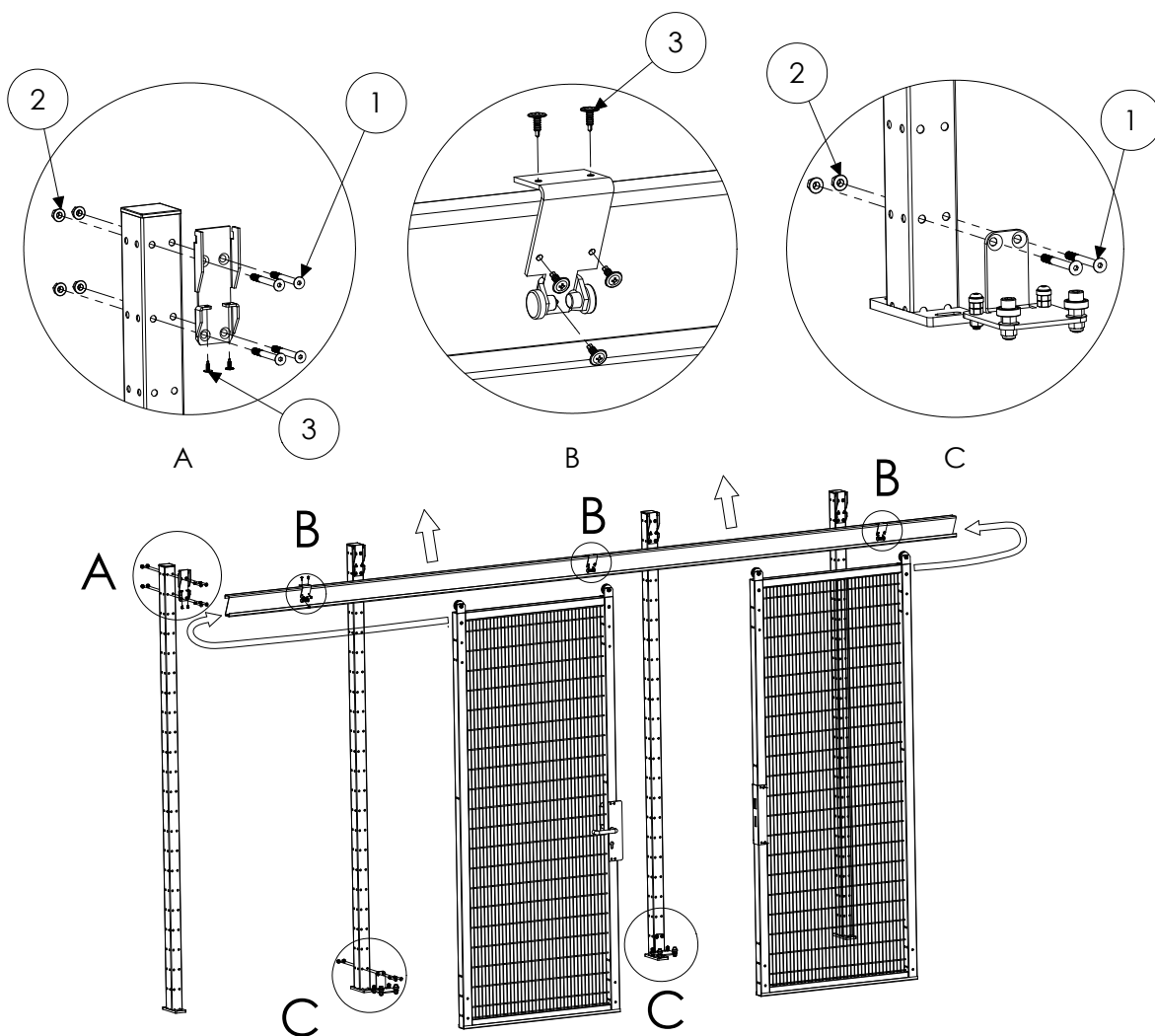
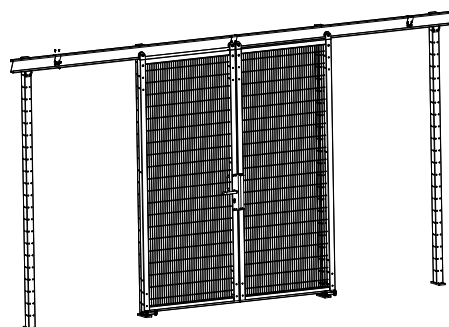
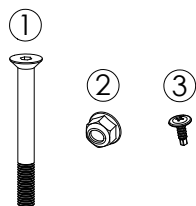
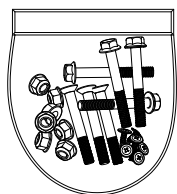



Double sliding door W 3000-4500

Puerta corredera doble A 3000-4500

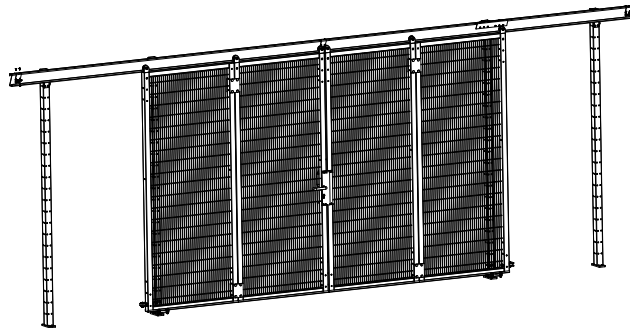

243-220-008

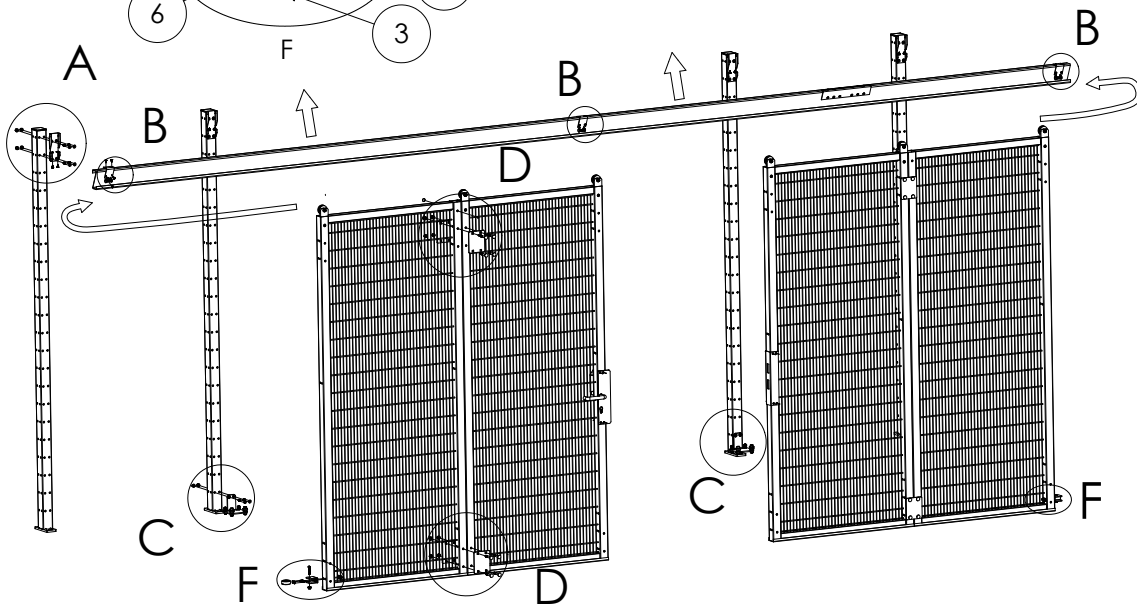
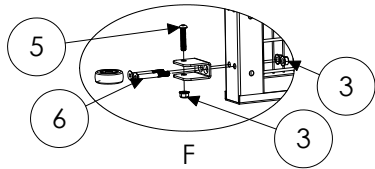
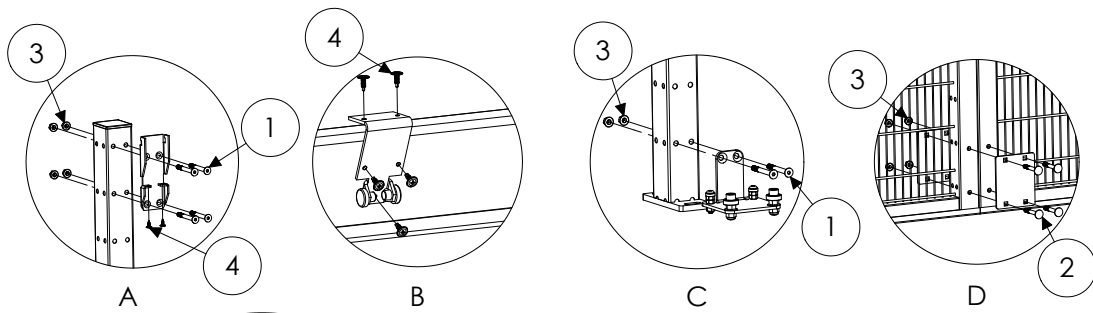
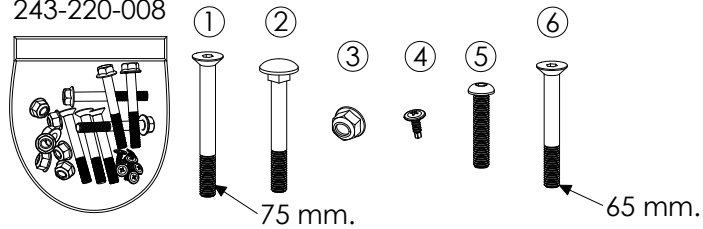

Sliding door H > 2200

Puerta corredera H > 2200

243-440-007

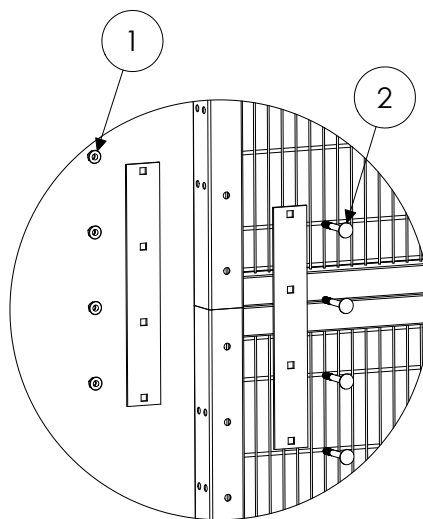
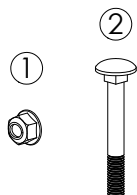
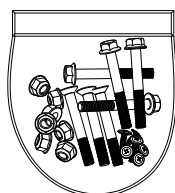

A

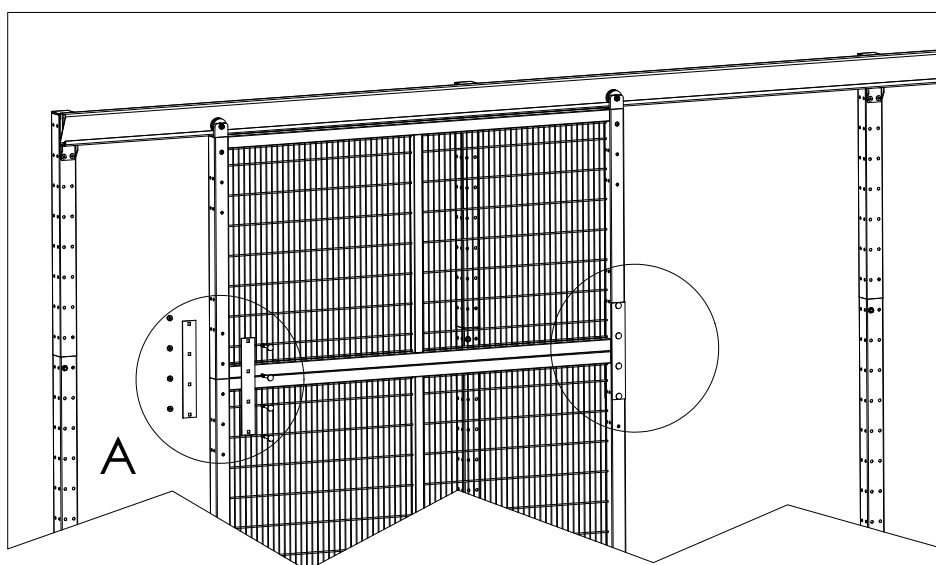

Double sliding door H < 2200

Puerta corredera doble H < 2200

243-440-008

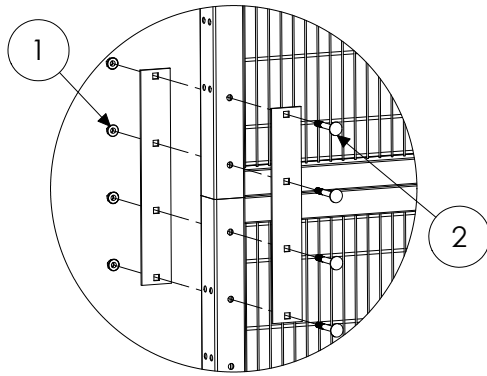
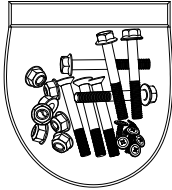

A

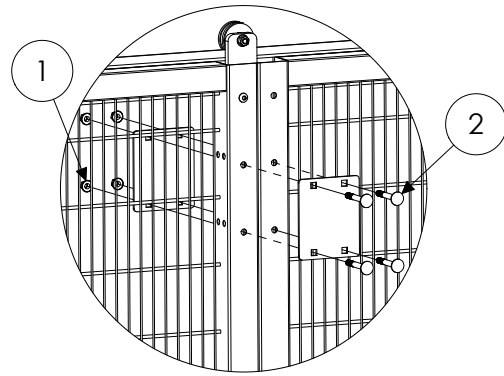

B

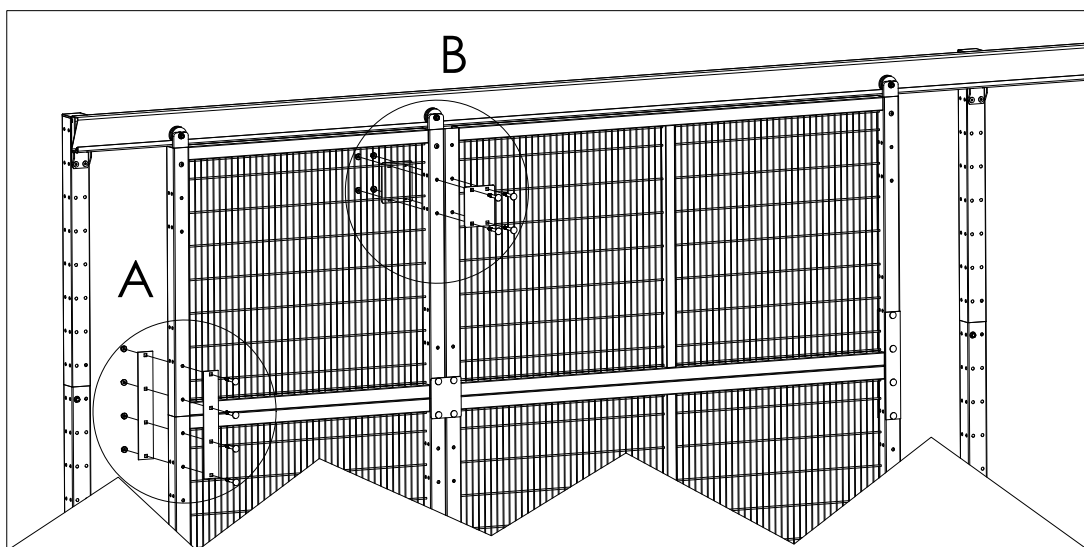

Single sliding door without top rail

Puerta corredera de una hoja sin riel superior

233-220-011

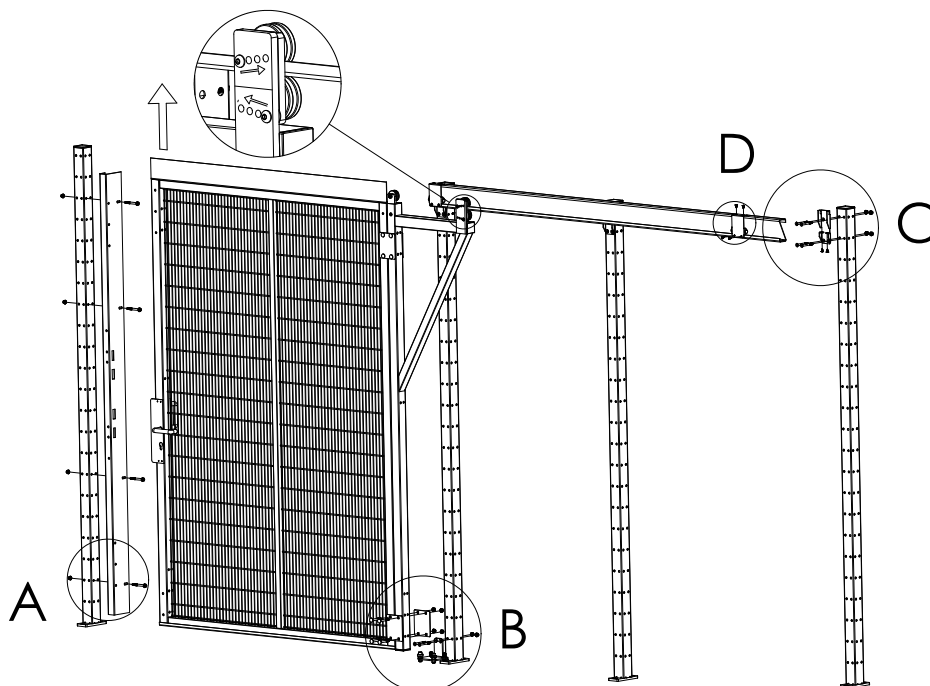
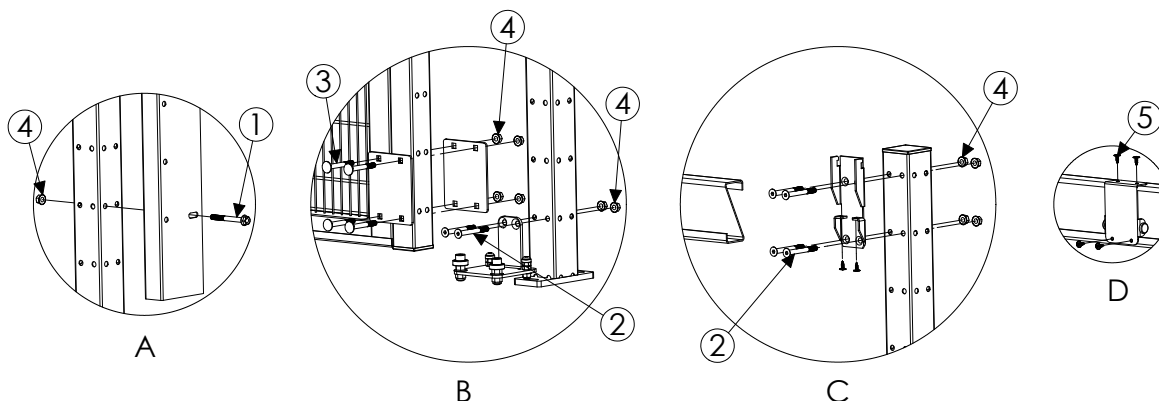
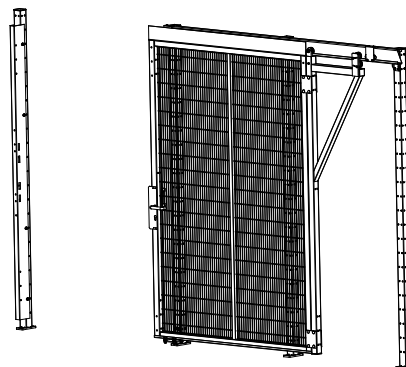
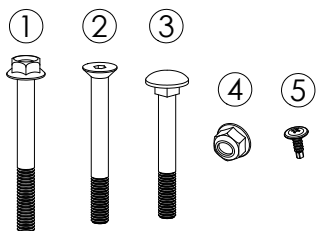
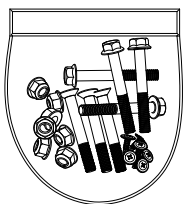

Double sliding door without top rail

Puerta corredera doble sin riel superior

233-220-013

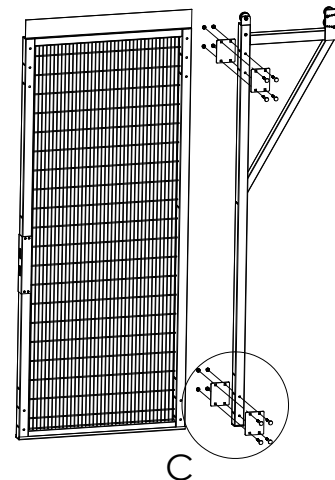
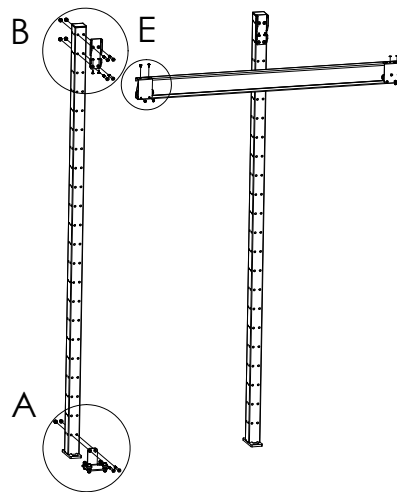
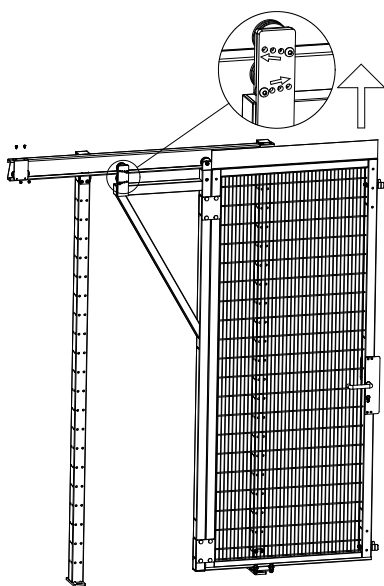
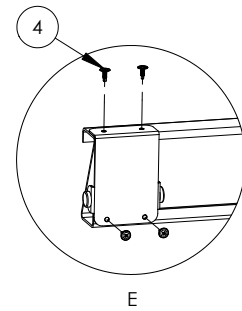
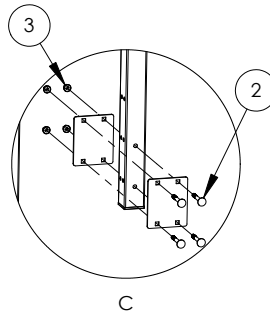
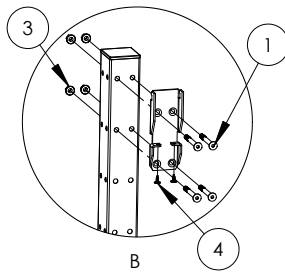
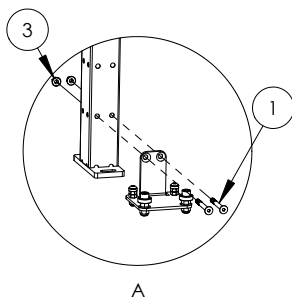
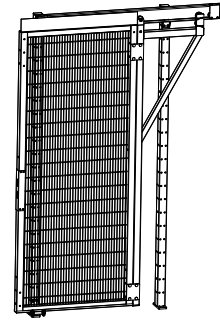
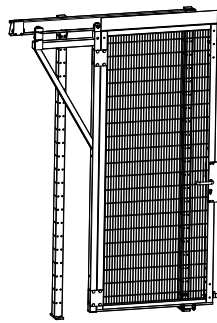
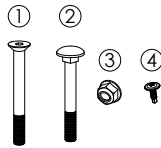
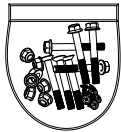

Padlock plates for single hinged door

Fijación para candado en puerta de una hoja

140-100-110

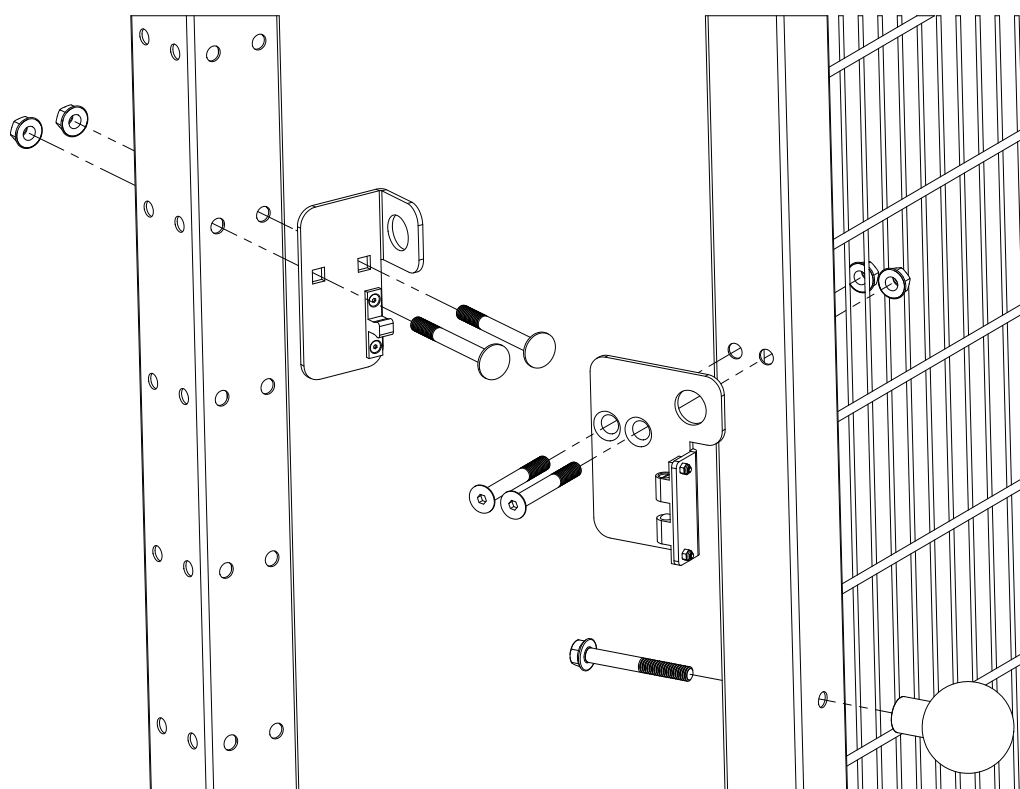
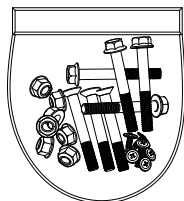

Padlock plates for double door

Fijación para candado en puertas de dos hojas

140-100-111

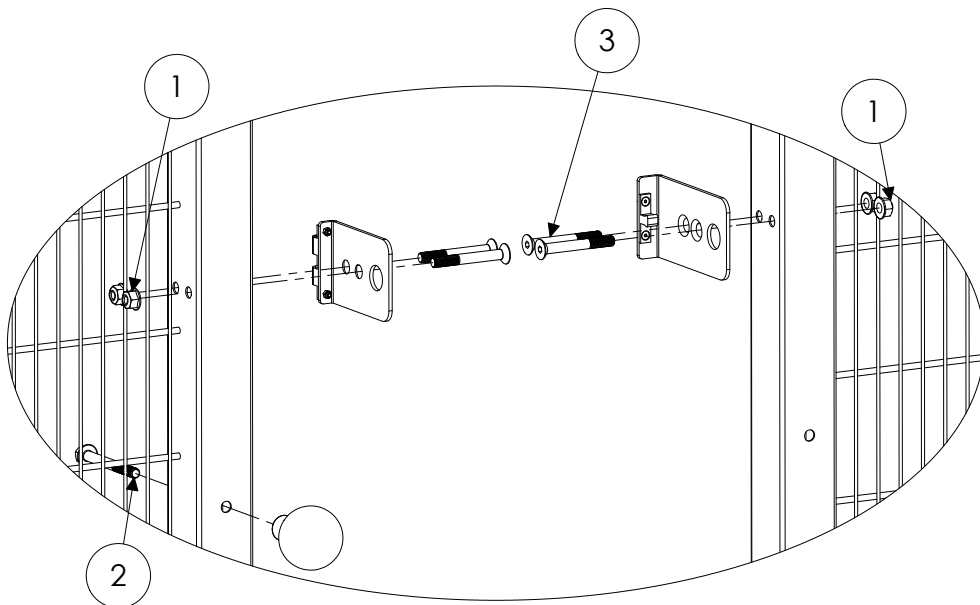
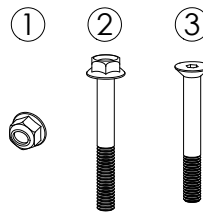
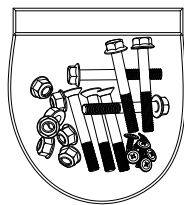

Padlock plates for single sliding door

Fijación para candado en puerta corredera de una hoja

140-100-112

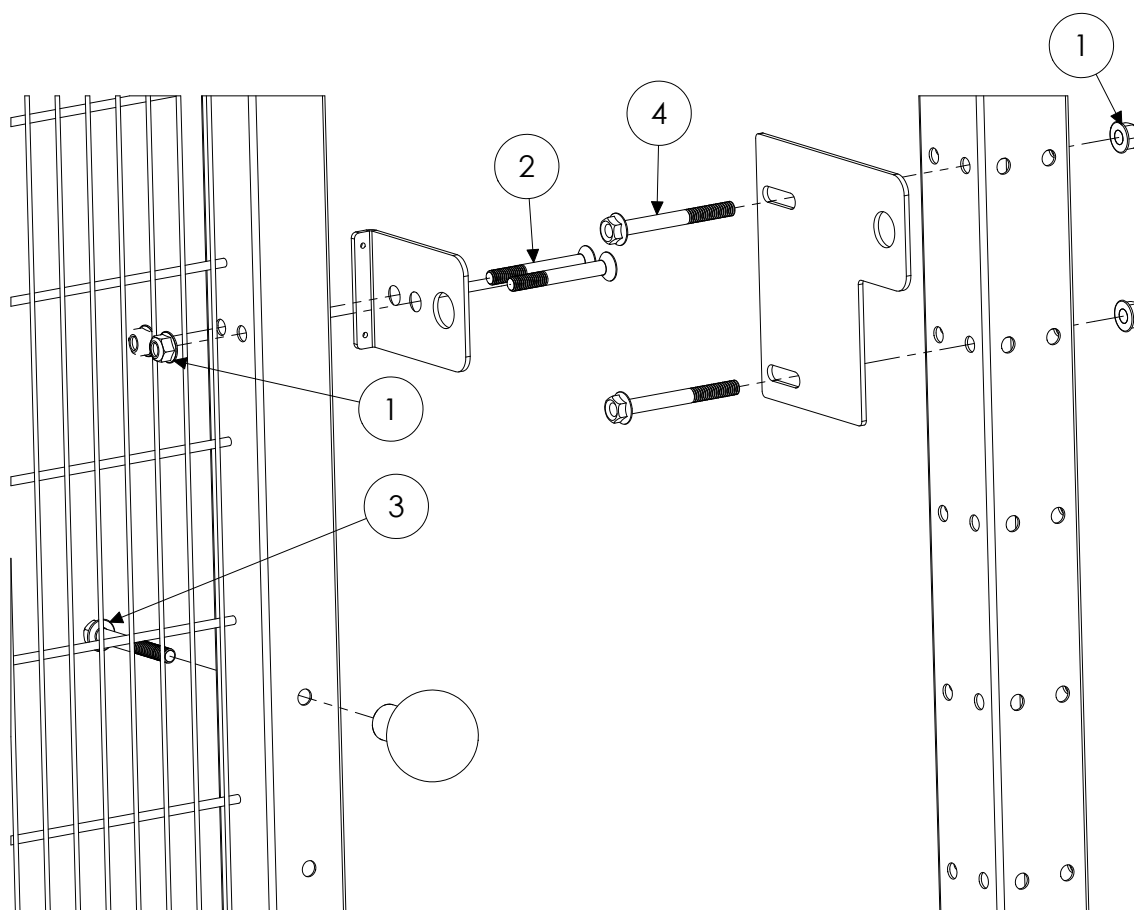
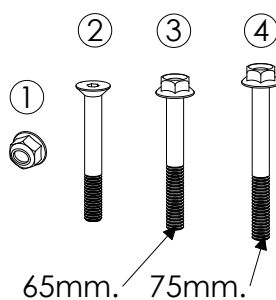
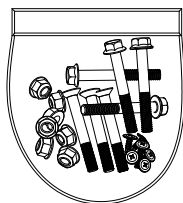



Cane bolt and switch fittings Schmersal AZ 16

Cerradura de pasador e interruptor Schmersal AZ 16

Left  
140-100-101

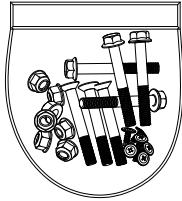

Right  
140-100-102

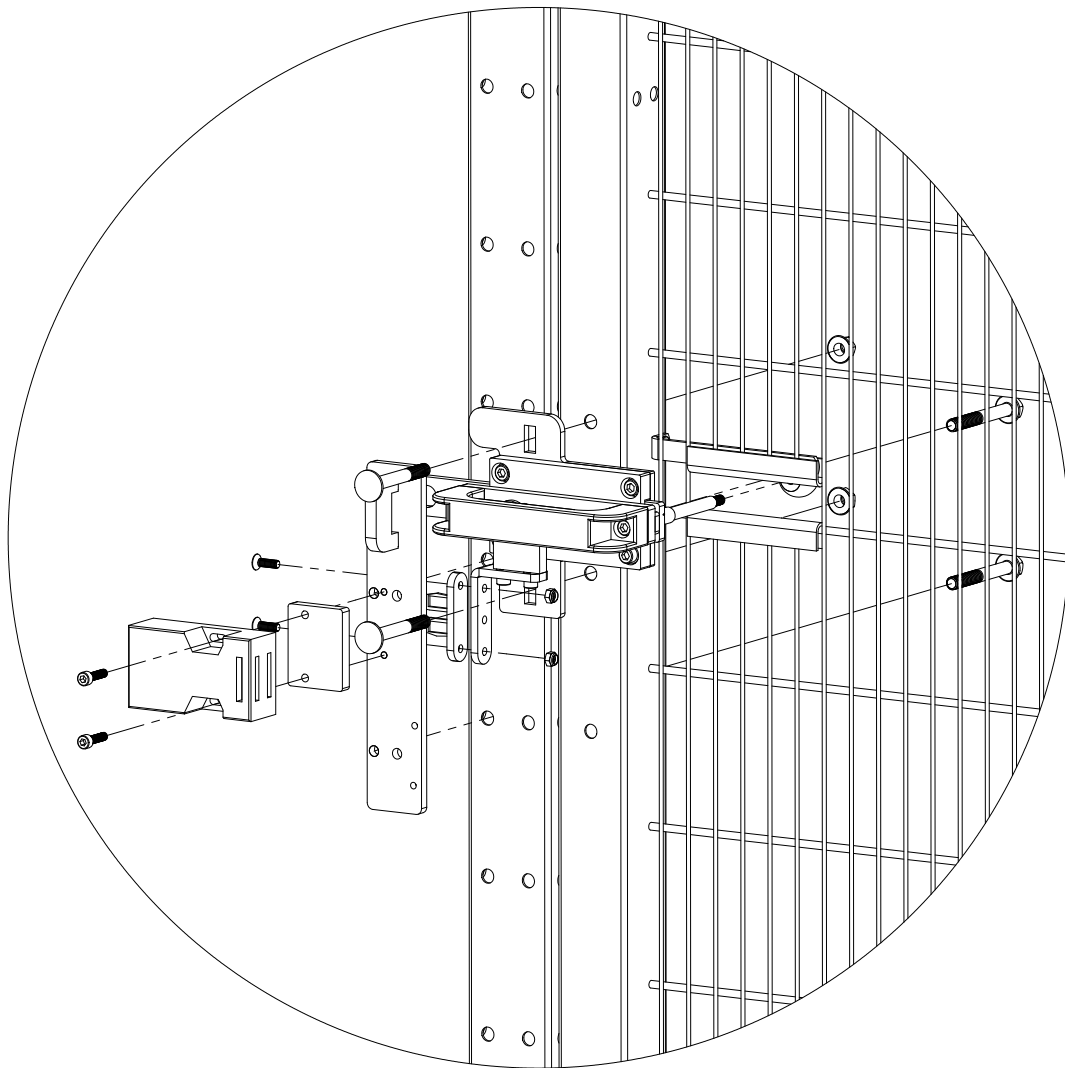
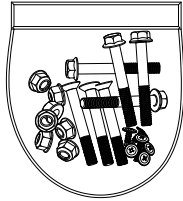

Cane bolt and switch fittings Euchner TZ

Cerradura de pasador e interruptor Euchner TZ

Left  
140-100-103

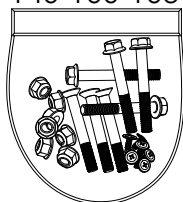

Right  
140-100-104

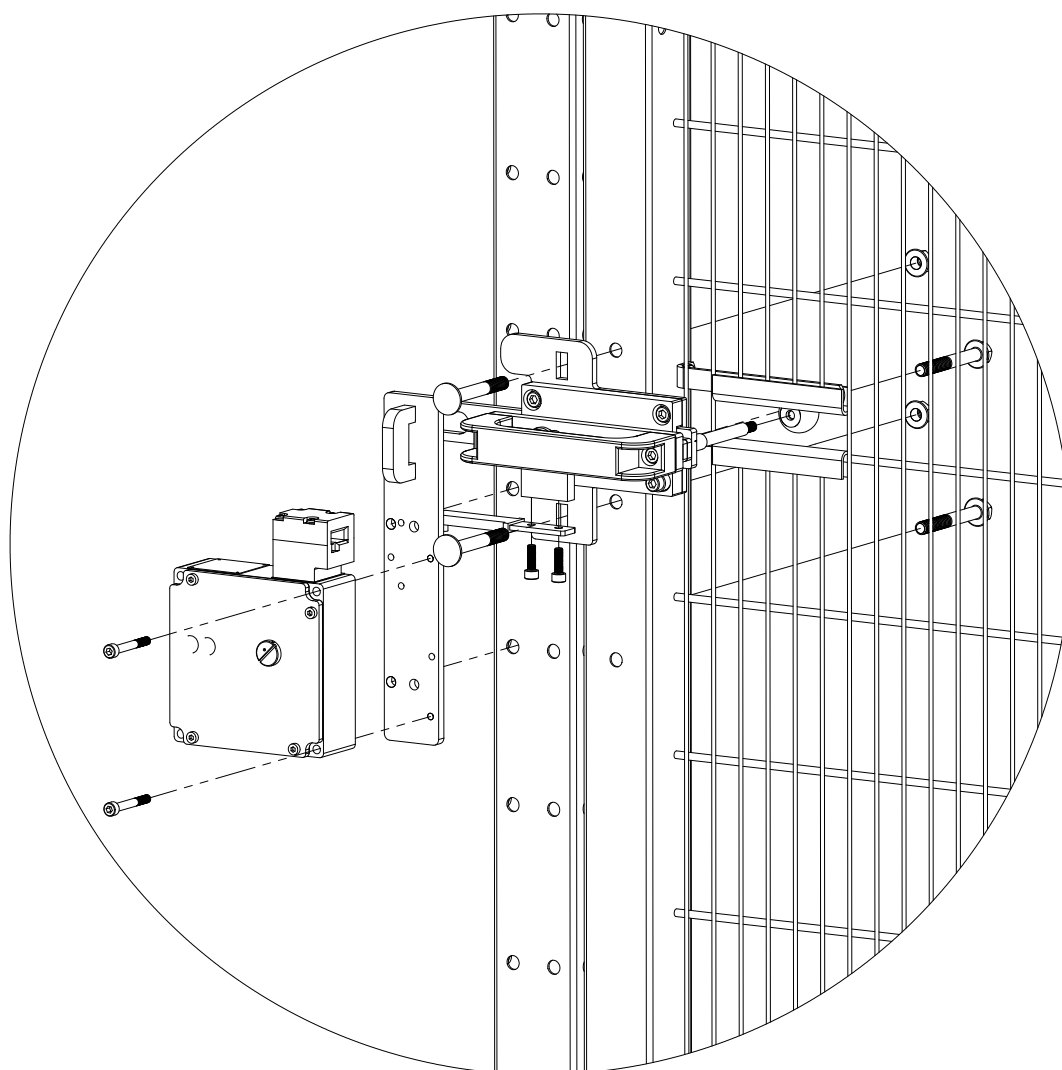
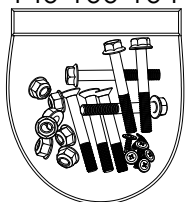

Cane bolt and switch fittings Euchner NZ

Cerradura de pasador e interruptor Euchner NZ

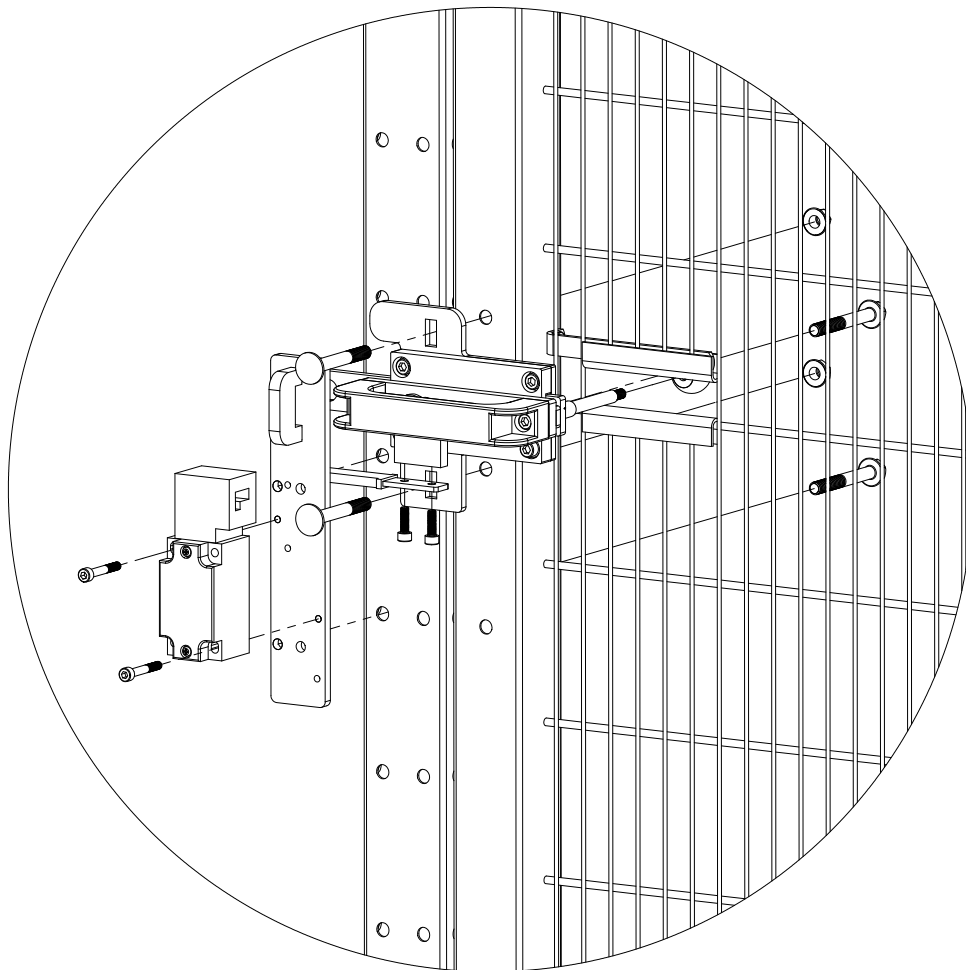
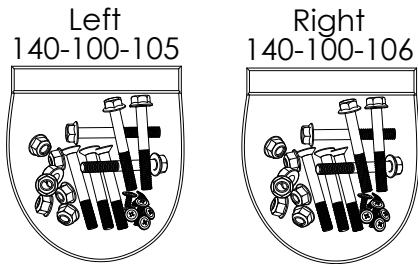

Cane bolt and switch fittings Siemens 3SE5

Cerradura de pasador e interruptor Siemens 3SE5

Left  
140-100-107

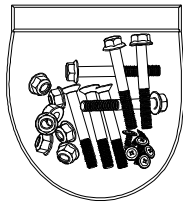

Right  
140-100-108

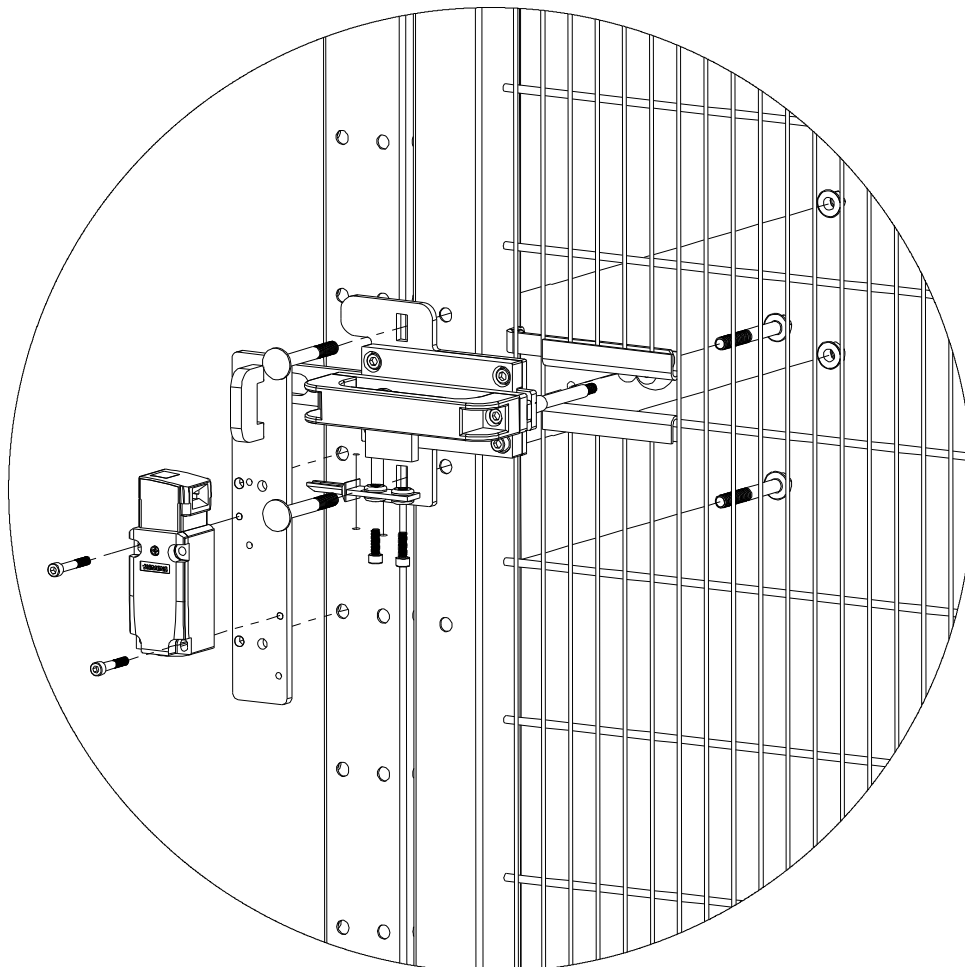
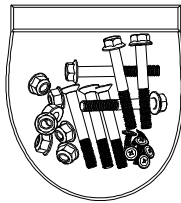

### Switch fittings for Schmersal AZM 200

#### Fijación de interruptor para Schmersal AZM 200

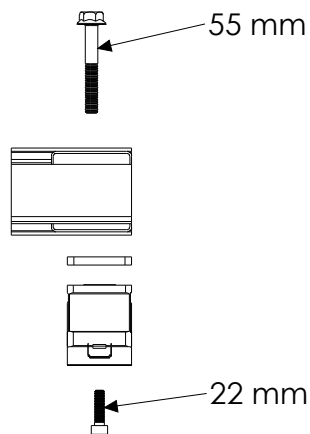

140-100-109

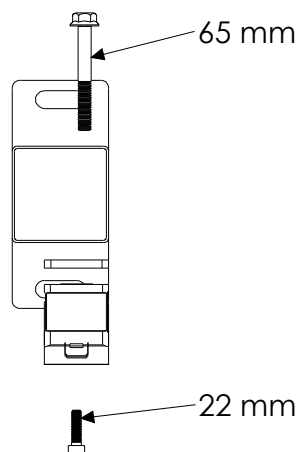
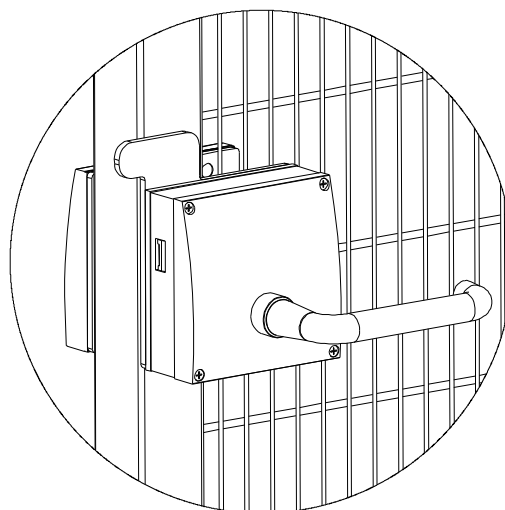
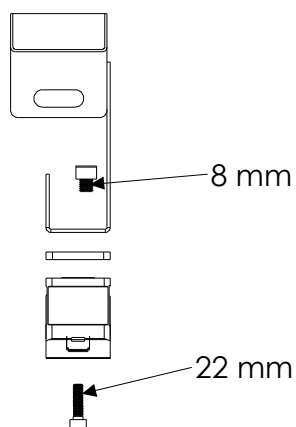
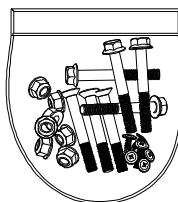

### Switch fittings for Euchner MGB

### Fijación de interruptor para Euchner MGB

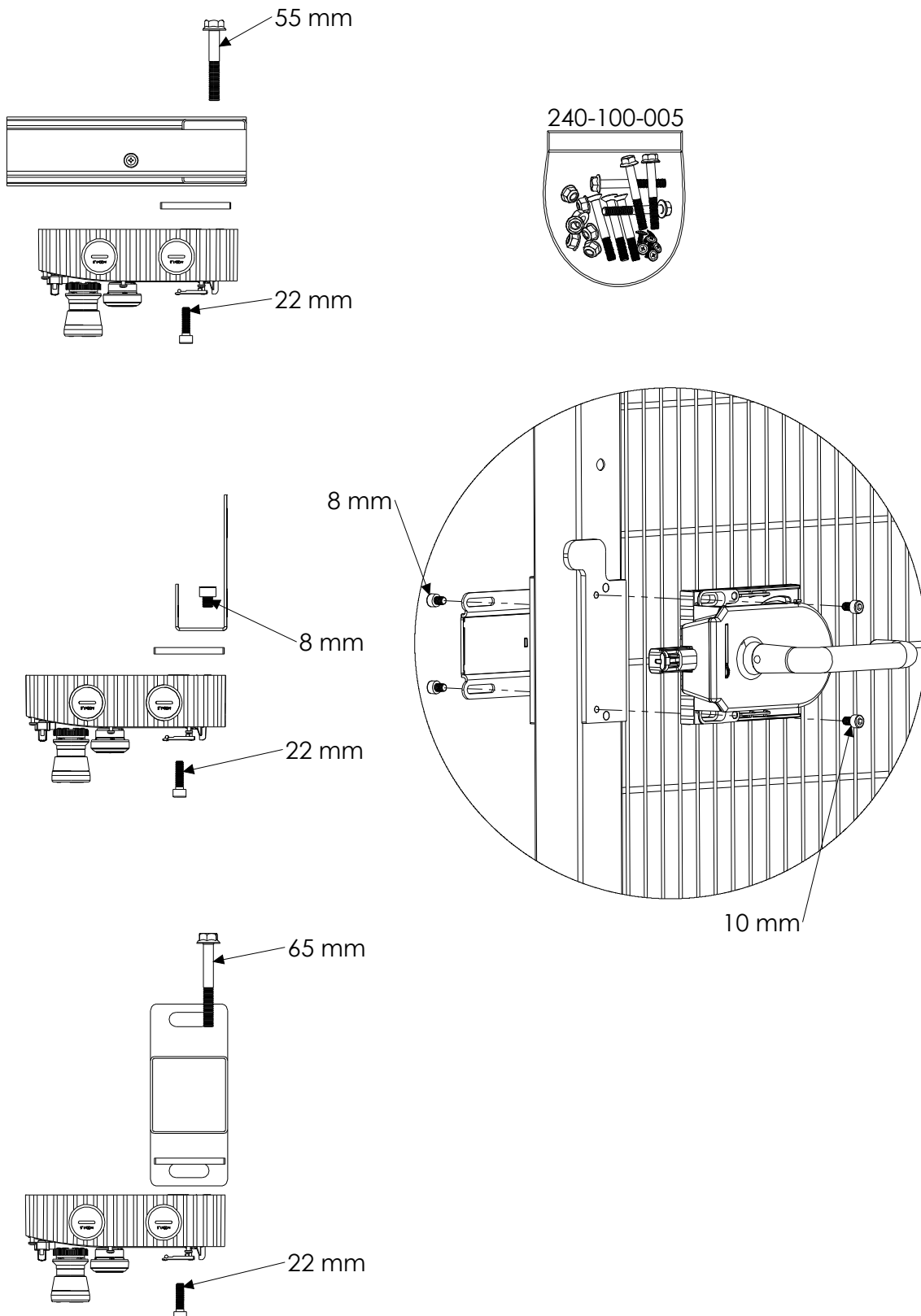

Bracket for hinge safety switch Schmersal TVS 410

Fijación para interruptor de seguridad Schmersal TVS 410

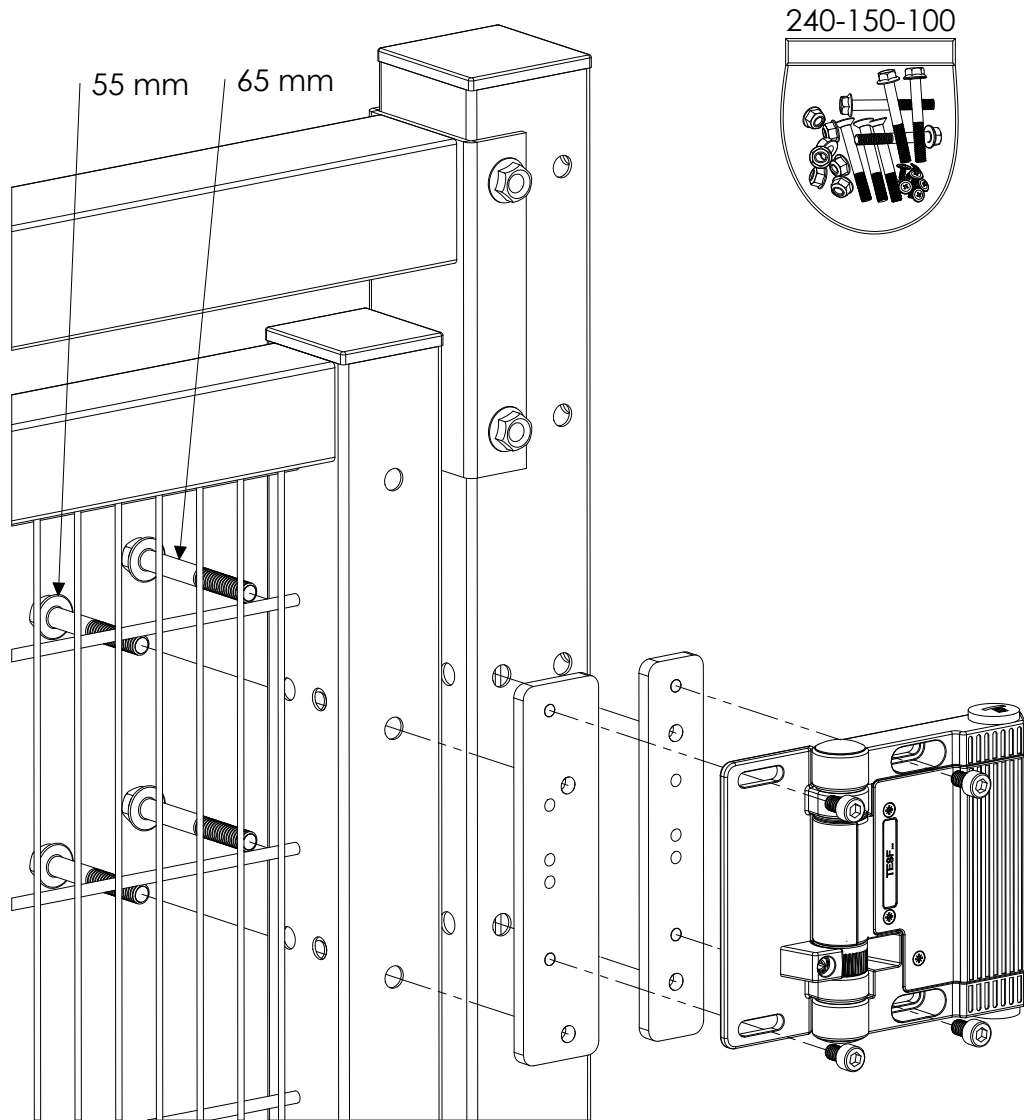

Handle for sliding door with switch

Manilla para puerta corredera con interruptor

140-000-970

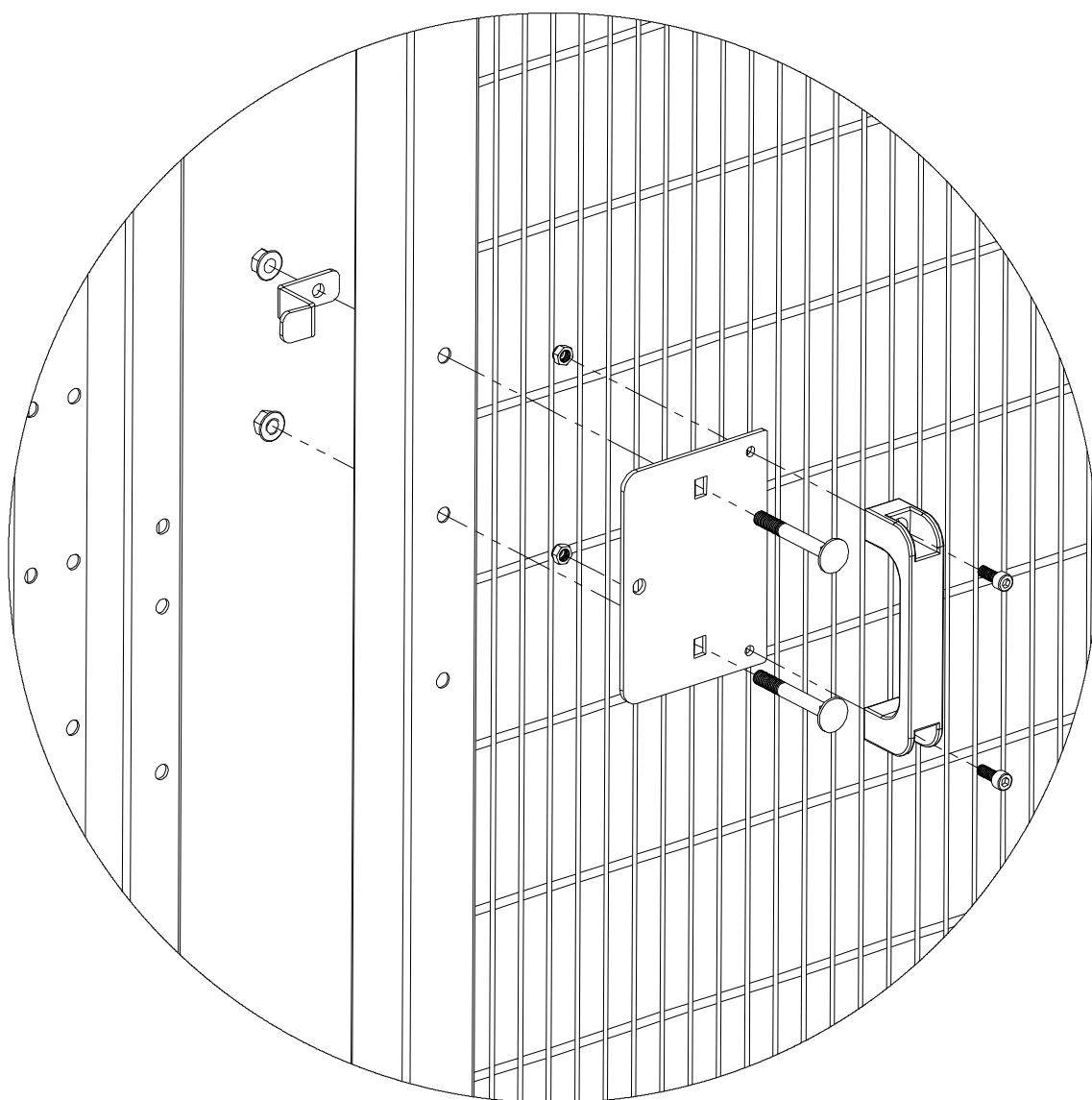
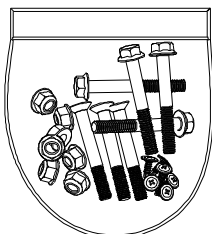



Switch fittings for sliding door Schmersal AZ 16

Fijación de interruptor - puerta corredera Schmersal AZ 16

240-100-003

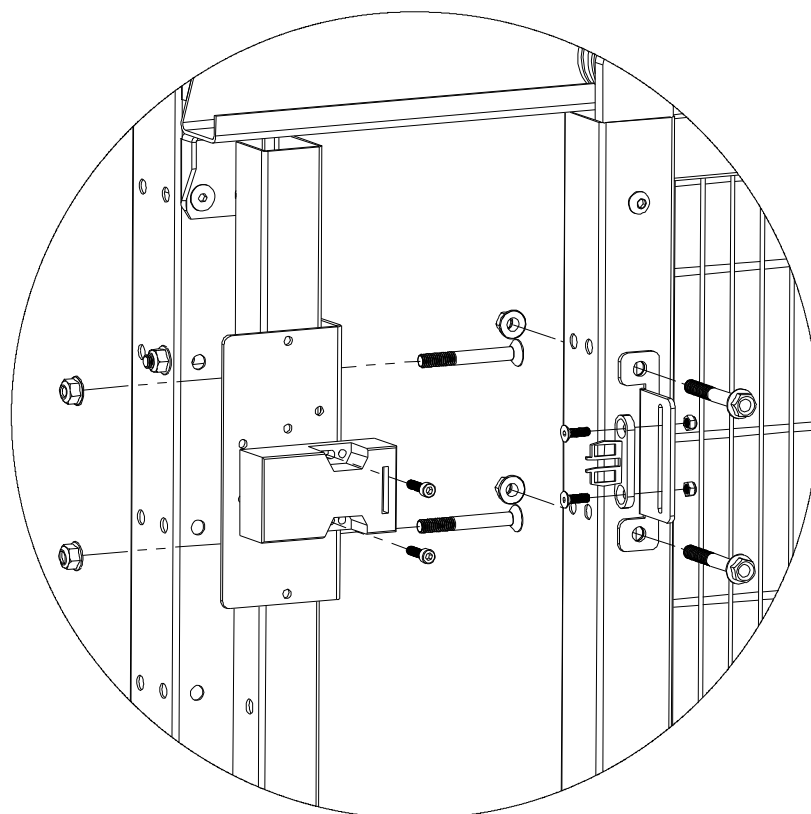
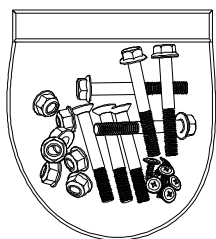

Switch fittings for sliding door Euchner TZ and NZ

Fijación de interruptor - puerta corredera Euchner TZ y NZ

240-100-001

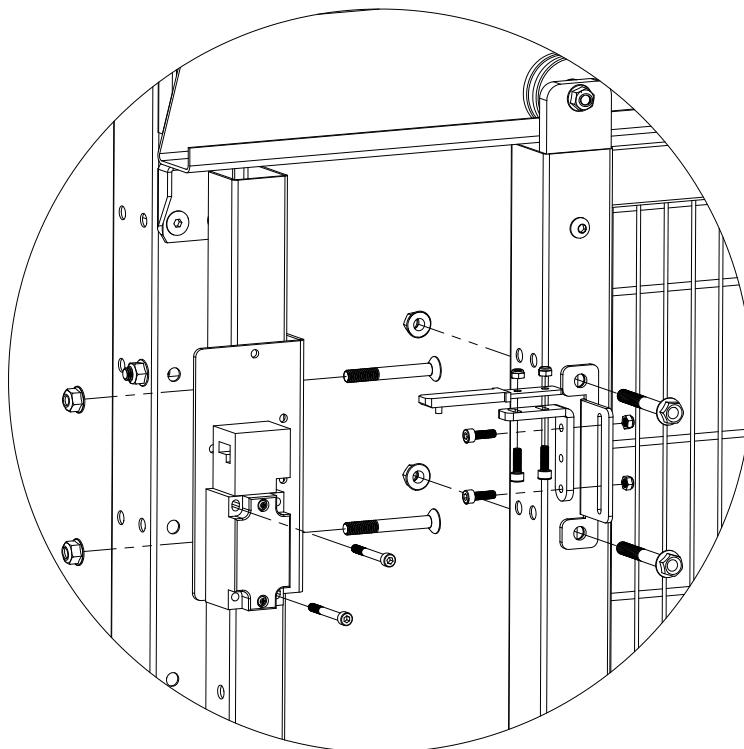
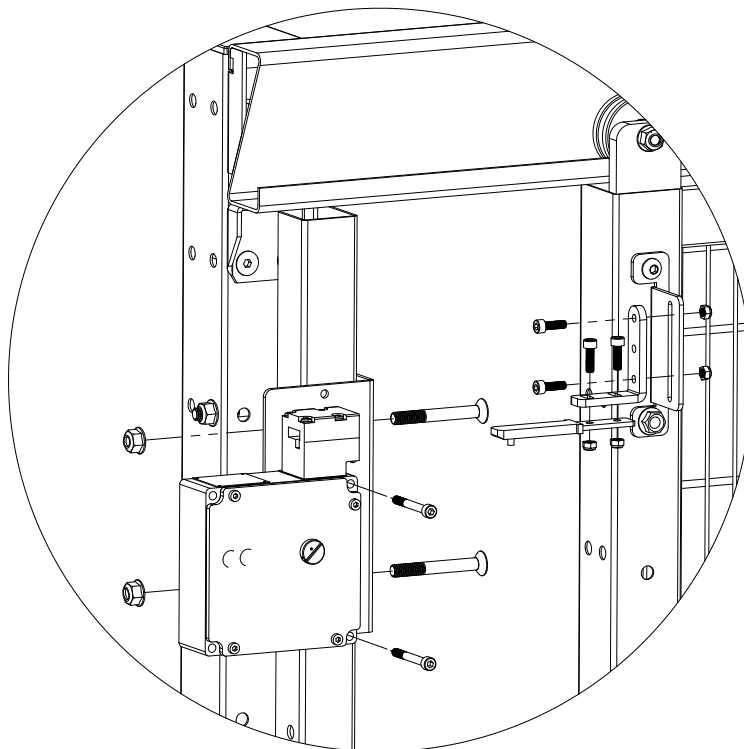
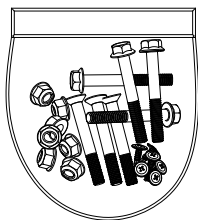

Switch fittings for sliding door Siemens 3SE5

Fijación de interruptor - puerta corredera Siemens 3SE5

240-100-004

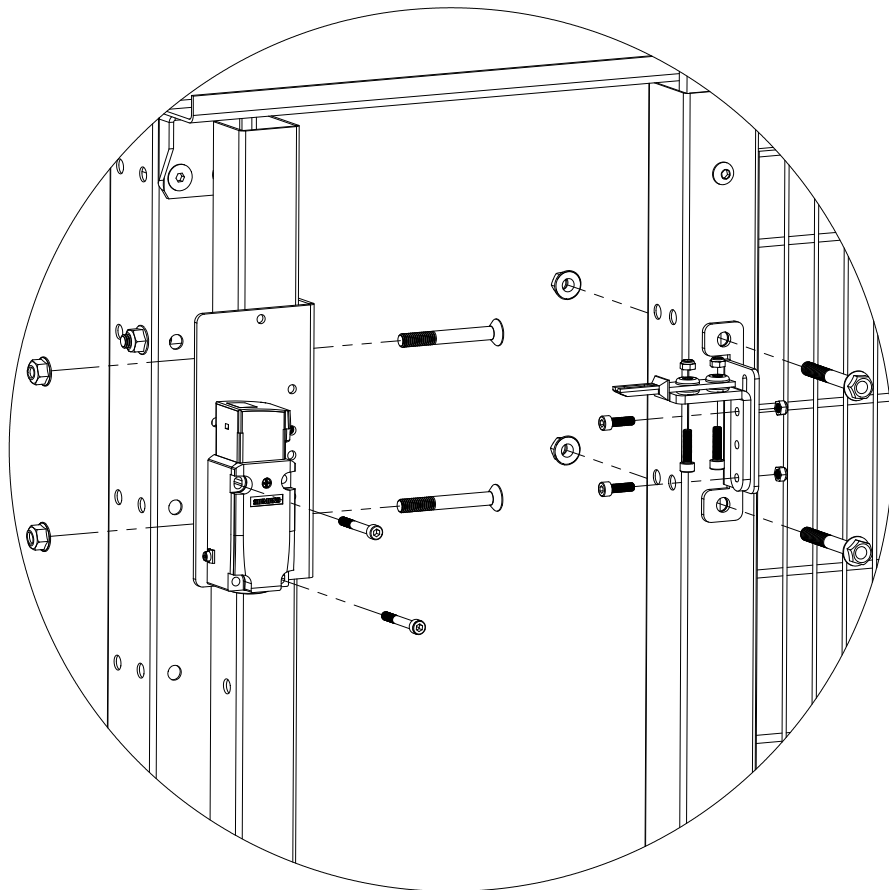
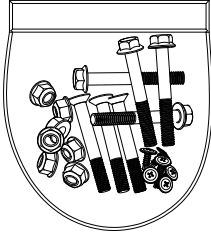

[www.aqdindustrial.com](http://www.aqdindustrial.com)



Delegación Barcelona: C/ Alba, 1 - 08520 Les Franqueses del Vallès (BCN) | 902 88 25 60

**aqd** Industrial Product  
